

Epping to Thornleigh Third Track

# Noise Barrier Consultation Addendum for the Urban Design and Landscape Plan

FEBRUARY 2016



Australian Government



HBO+EMTB







<b>1. Introduction</b>	<b>5</b>	<b>3. Concept Design</b>	<b>17</b>
1.1 The Project	5	3.1 Acoustic engineering parameters: barrier locations and heights	17
1.2 Purpose of this document and relationship to Urban Design and Landscape Plan and the Operational Noise and Vibration Review	6	3.2 Barrier type	18
1.3 Changes to the look and feel of noise barriers as a result of community feedback	7	3.3 Landscape design	20
1.4 The noise barrier proposal	8	3.4 Noise Barrier 01: Along Sutherland Road near Beecroft Station	22
1.5 Applicable Conditions of Approval	10	3.5 Noise Barrier 02: Along Wongala Crescent between approximately 49 and 107 Wongala Crescent	28
1.6 Consultation	11	3.6 Noise Barrier 03: South of Pennant Hills Road	34
1.7 Feedback summary	12	<b>4. Contextual analysis and landscape assessment</b>	<b>39</b>
1.8 Ongoing and future communications	13	4.1 Contextual analysis	39
<b>2. Urban and landscape design objectives and principles for the noise barriers</b>	<b>15</b>	4.2 Landscape assessment	41
2.1 Relationship to UDLP Vision	15	<b>5. Augmented visual impact assessment</b>	<b>45</b>
2.2 Urban design objectives	15	5.1 Purpose	45
2.3 Urban design principles	15	5.2 Timing	45
		5.3 Methodology	45
		5.4 Summary of Findings	47
		5.5 At-receiver landscaping treatment	47
		Appendix A Relevant Standards	49
		Appendix B Community Feedback	51
		Appendix C Landscape Maps	59

This page has been intentionally left blank



# 1. Introduction

## 1.1 The Project

The Epping to Thornleigh Third Track (ETTT) Project comprises the construction of six kilometres of new and upgraded rail track on the western side of the existing tracks and related works within the rail corridor between Epping and Thornleigh stations in northwestern Sydney. The new (third) track will separate northbound freight from all-stops passenger train movements along the steep incline between Epping and Thornleigh.

The overall goal is to help provide additional capacity for northbound (interstate container) freight trains, particularly during the daytime when passenger trains currently have priority.

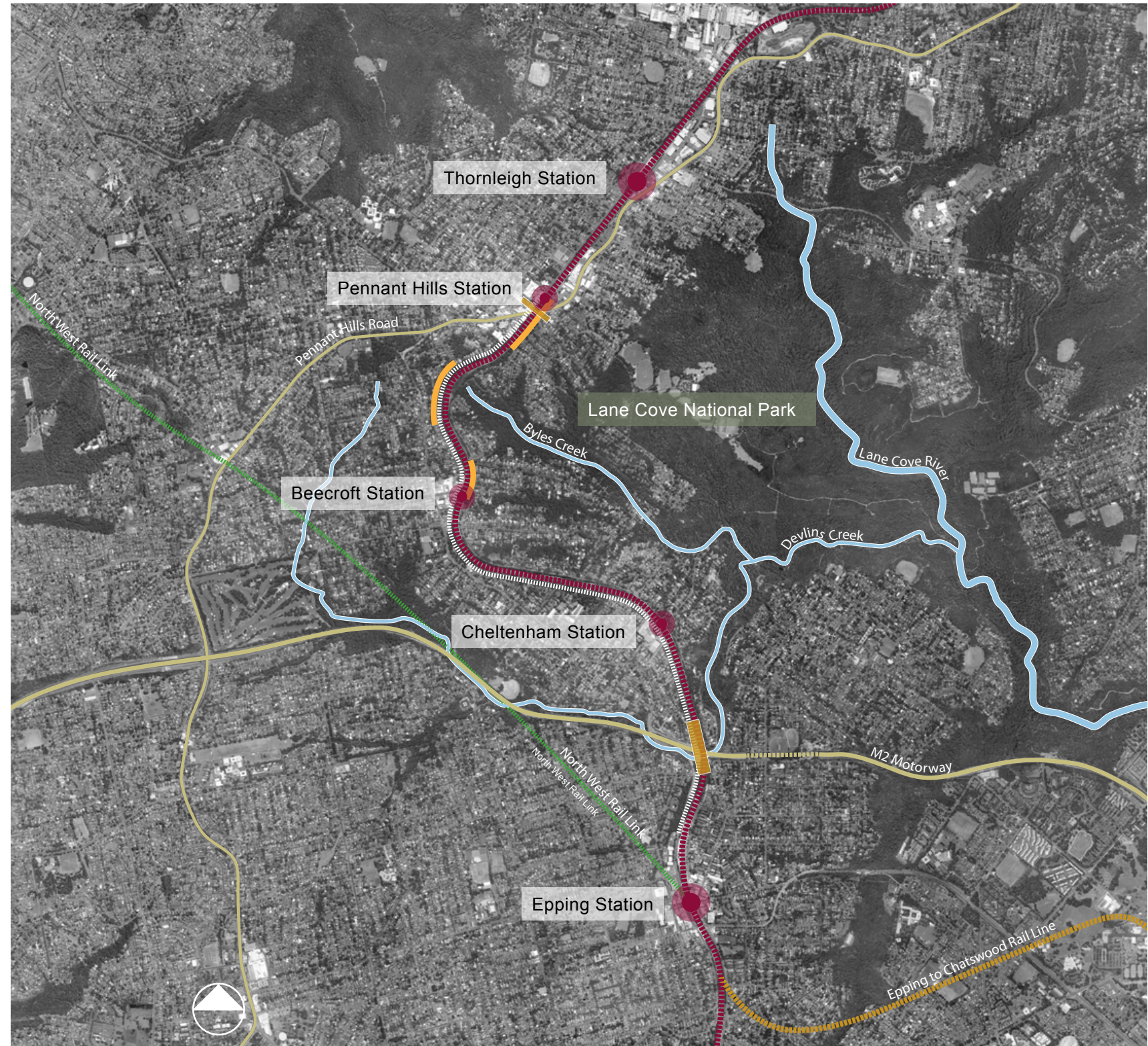
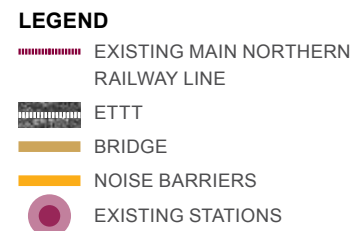

Figure 1-1 ETTT subject area site context



## 1.2 Purpose of this document and relationship to Urban Design and Landscape Plan and the Operational Noise and Vibration Review

The ETTT Project Conditions of Approval required the preparation of an Operational Noise and Vibration Review (ONVR), to assess noise and vibration impacts associated with the operation of the Epping to Thornleigh Third Track (ETTT).

The ONVR was released for public comment in May 2014 and was approved by the Department of Planning and Environment (DP&E) in December 2014.

The ONVR noted that the predicted noise levels at various properties are expected to exceed the Environment Protection Authority (EPA) noise trigger guideline. To mitigate this, three noise barriers are being installed along the rail corridor:

1. Noise Barrier 01: On the up side, between Copeland Road and Chapman Avenue bridges at Beecroft Station.
2. Noise Barrier 02: On the down side, between approximately 49 and 107 Wongala Crescent, Pennant Hills.
3. Noise Barrier 03: On the up side, between approximately Hampden Road and 15 Cassia Grove, Pennant Hills.

The visual impacts on nearby properties from these noise barriers were not described in the previously approved Urban Design and Landscape Plan (UDLP), as the location and extent of noise barriers had not been determined at the time that document was published.

As the design of the required noise barriers is now progressed, the ETTT Project completed targeted consultation with properties that are either directly adjacent to the new noise barrier or that are likely to have some direct visual impact from the noise barrier construction.

This Addendum focuses on the proposed in-corridor noise barriers for noise mitigation for the ETTT Project. It follows on from, complies with and implements the recommendations contained in the ONVR.

This report is intended to be read in conjunction with, and as an extension of, the UDLP prepared subsequent to and on the basis of the project EIS (September 2012), Submissions Report (March 2013) and the Operational Noise and Vibration Review (ONVR). In addition to a description of the design of the three proposed barriers, it includes an account of the community consultation undertaken specifically for the barriers and modifications made to the designs as a result of the consultation process.

In general, this report adopts the structure and format of the approved ETTT Project UDLP. It comprises the following sections:

- Introduction
- Urban and landscape design objectives and principles for the Barriers
- Concept design – a description of the proposed noise barrier designs, including structural system, panel type, materials, finishes, colours, maintenance (anti-graffiti strategy)
- Contextual analysis and landscape assessment – a description of the visual, landscape and cultural/heritage qualities of the immediate context surrounding the barriers
- Augmented visual impact assessment – visual impacts of the proposed barriers and recommended urban and landscape design strategies to, where possible, mitigate these impacts and enhance the immediate context
- Appendices.

Community feedback has been considered in the finalisation of the barrier designs. Key issues raised by the community with respect to the urban design aspects of the barriers and associated landscape works were:

- Appropriate re-vegetation to provide visual buffers
- Management of graffiti
- Noise barrier colour.



## 1.3 Changes to the look and feel of noise barriers as a result of community feedback

During the community consultation period, 72 written submissions were received from the community. The majority of the submissions provided the residents' preference with regards to the noise barrier colour options and proposed vegetation species. The consultation period did not result in any additional changes to the proposed design.

### Noise barrier colour preferences:

The most popular colour for all three noise barriers was 'Mist Green' and as such all 3 noise barriers will be painted 'Mist Green'.

Colour	Mist Green	Smoke Ash	Cola (Dark Brown)
Popularity	82.2%	16.4%	1.4%

### Vegetation preferences:

The most popular vegetation preferences will be planted along Noise Barriers 1 and 2, Noise Barrier 3 has no revegetation proposed as only minor trimming and clearing is required. The most popular tree species at these locations were

- Noise Barrier 1 – the most preferred tree is Blueberry Ash, shrub is Coffee Bush and ground cover is False Bracken.
- Noise Barrier 2– the most preferred tree is Blueberry Ash, shrub is Narrow Leaved Geebung and ground cover is False Bracken.

### Planting creeper plants/vines:

The ETTT Alliance received several suggestions to plant creeper plant/vines along the noise barriers to assist with the proposed visual impact mitigation but also graffiti management. Following consultation with Sydney Trains creepers or vines cannot be planted along the noise walls due to the adverse effect on the longevity of the noise barriers and reducing visibility during maintenance inspections.

## 1.4 The noise barrier proposal

Three separate noise barriers will be constructed within the rail corridor at the following locations (refer Figure 1-2):

- Noise Barrier 01 (NB01) at Beecroft Station, on the east side of the railway between Copeland Road and Chapman Avenue Bridges.
- Noise Barrier 02 (NB02) on the west side of the railway between approximately 49 and 107 Wongala Crescent, Pennant Hills.
- Noise Barrier 03 (NB03) on the south side of the railway between approximately Hampden Road and 15 Cassia Grove, Pennant Hills.

The specific location, length and height of each barrier was determined by the ETTT Project's acoustic consultant as part of the ONVR, with structural engineering and construction inputs.

The noise barriers will be made from aerated concrete panels. This is an effective material to reduce noise impacts as it is a solid barrier that interrupts the path of noise. Both sides will be painted in a colour chosen by the local community.

The urban design approach being pursued is to deliver a clean, simple and refined appearance, with hardware such as bolts and fixing clips which are as small and visually unobtrusive as possible.

Where possible and appropriate, new landscaping will be provided to replace existing vegetation which must be removed for construction of the barriers. The landscaping intention is to maximise visual screening of the barriers while using species already outlined in the UDLP and based on community feedback during the recent consultation.

### 1.4.1 Key impacts

Key impacts identified as a result of the noise barrier construction are visual impacts from the construction of a new solid barrier as well as removal of existing vegetation to allow the installation works to be completed. These impacts were also reflected in the community feedback received during the consultation period.





Figure 1-2 Proposed Noise Barriers

## 1.5 Applicable Conditions of Approval

The Director General's Conditions of Approval which relate to the proposed noise barriers are addressed in this report as follows:

Condition 31 (C31) - A Design and Landscape Plan shall be prepared and implemented for the SSI. The Plan shall be prepared by appropriately qualified person(s) in consultation with RailCorp, relevant Councils and the community and shall present an integrated design and landscape plan for the SSI. The Plan shall include, but not necessarily be limited to:

Requirement	Location in Report
a) identification of design principles and standards based on: <ul style="list-style-type: none"> <li>i. local environmental and heritage values</li> <li>ii. urban design context</li> <li>iii. sustainable design and maintenance</li> <li>iv. transport and land use integration</li> <li>v. passenger and community safety and security</li> <li>vi. community amenity and privacy</li> <li>vii. relevant design standards and guidelines such as the NSW Sustainable Design Guidelines for Stations (v2.0, TfNSW, 2011), Bridge Aesthetics Design guidelines to improve the appearance of bridges in NSW (RMS, 2012), Guidelines for the Development of Public Transport Interchange Facilities (Ministry of Transport, 2008) and Crime Prevention Through Environmental Design Principles (Department of Urban Affairs and Planning, 2001), and relevant Agency and Council design standards.</li> </ul>	Refer to Section 02
b) the location of existing and retained vegetation and landscaping;	Refer to Section 03
c) a description of disturbed areas and details of the strategies to progressively rehabilitate regenerate and/ or revegetate these areas. Details of species to be replanted/ revegetated shall be provided, including their appropriateness to the area and habitat for threatened species;	Refer to Section 03
d) specific measures to limit the visual impacts of the proposed elevated concourse of Cheltenham Station, including limiting privacy and overshadowing impacts;	n/a
e) design details of built elements (retaining walls, bridges, viaducts, stations, parking areas etc.) and measures to minimise the impact of these elements, including an embankment and retaining wall plan that avoids, where feasible and reasonable, the use of shotcrete;	Refer to Sections 03 and 05

Requirement	Location in Report
f) an assessment of the visual screening effects of existing vegetation and the proposed landscaping and built elements. Where receivers have been identified as likely to experience a moderate or high visual impact as a result of the operation and residual impacts are likely to remain, the Proponent shall, in consultation with affected receivers, identify opportunities for providing at-receiver landscaping to further screen views of the SSI. Where agreed to with the landowner, these measures shall be implemented during the construction of the SSI;	Refer to Section 05
g) graphics such as sections, perspective views and sketches for key elements of the SSI, including, but not limited to built elements of the SSI;	Refer to Sections 03 and 05
h) monitoring and maintenance procedures for the built elements (including graffiti management), rehabilitated vegetation and landscaping (including weed control) including performance indicators, responsibilities, timing and duration and contingencies where rehabilitation of vegetation and landscaping measures fail; and	Refer to Section 03
i) evidence of consultation with the relevant council and community on the proposed urban design and landscape measures prior to its finalisation. Purpose of this document is for community engagement.	Refer to Section 06



## 1.6 Consultation

The ETTT Project acknowledges that construction of noise barriers is likely to have visual and vegetation impacts on some nearby properties. These impacts were not described in the currently-approved Urban Design and Landscape Plan (UDLP), as the location and extent of noise barriers had not been determined at the time that document was published.

As the design of the required noise barriers has now progressed, the ETTT Project completed targeted consultation with properties that are either directly adjacent to the new noise barrier or that are likely to have some direct visual impact from the noise barrier construction.

### Previous consultation

It is acknowledged that to date, strong community feedback has been received regarding existing and future operational noise and vibration concerns. During the EIS exhibition phase, a total of 426 submissions were received from the community with majority concerning operational noise and vibration. These concerns were also mirrored in the community submissions during the UDLP consultation in late 2013, as well as over 54 written submissions which were received during the public display of the ONVR in mid-2014.

### September/October 2015 consultation

The ETTT Project's Conditions of Approval require consultation with the local council and community on the proposed urban design and landscape measures prior to it being finalised. At the time the UDLP was developed and consulted on, noise barriers were not included in the project design and as such the UDLP stated that:

*As with property treatment, it is too soon to confirm the requirements for noise walls. However noise walls will be considered and assessed as part of the ONVR process. Should the ONVR identify that noise walls are required, additional consultation with affected communities will be undertaken.*

Consultation about the appearance of proposed noise barriers was undertaken with directly affected community members between Thursday 24 September and Friday 9 October, 2015. This included those properties directly in front of the proposed noise barriers and those that will have a direct visual impact from them. The noise barrier consultation was focused on the look and feel of the barriers and its findings will become an addendum to the already-approved UDLP and the ONVR. The objectives of this community consultation were to:

- Fulfil the requirements of the ETTT Project's Conditions of Approvals regarding urban design and landscaping
- Explain how previously identified concerns relating to look and feel of the noise barriers have been addressed.
- Give directly affected property owners an opportunity to provide feedback on the proposed design of the noise barriers before the UDLP/ONVR addendum is submitted to DP&E
- Outline next steps including how community feedback is adopted, project approvals, when noise barriers will be constructed etc.

The table below outlines key engagement tools and activities that were implemented as part of the consultation process:

Table 1-1 **Community engagement tools**

Engagement tool/activity	Purpose and activity
Letter, flyer and feedback form to properties deemed as directly affected	Three specific communications packs were sent to the 210 properties identified as directly affected by the three noise barriers. The communication packs outlined the consultation process; noise barrier design including colour and type; proposed landscaping; explained next steps; and asked for feedback on the proposed look and feel of the noise barriers.
Website	Created a section on the project website titled 'Noise Barrier colour and vegetation options' where the various other ONVR and UDLP information is available to view ( <a href="http://www.transport.nsw.gov.au/projects-northern-sydney-freight-corridor-program/epping-thornleigh-third-track/current-works">http://www.transport.nsw.gov.au/projects-northern-sydney-freight-corridor-program/epping-thornleigh-third-track/current-works</a> ) .  The website also included an online survey where adjacent properties could select their preferred noise barrier colour and re-vegetation options, and provide feedback on the proposed look and feel of the noise barriers.
Community group briefings	Briefings were offered to the Pennant Hills District Civic Trust and the Beecroft Cheltenham Civic Trust.
Other briefings	A briefing was also provided to NSW Department of Planning & Environment

## 1.7 Feedback summary

During the community consultation period, 72 written submissions were received from the community. The majority of the submissions provided the residents' preference with regards to the noise barrier colour options and proposed vegetation species. The consultation period did not result in any additional changes to the proposed design. Feedback received was about various items including

### Look and feel of NB01 – Beecroft Station noise barrier

- The most popular colour choice for the noise barrier was Mist Green with over 85% of respondents choosing it.
- The proposed masonry sections of the barrier were supported.
- The most popular tree was Blueberry Ash with close to 80% respondents choosing it and the remainder selecting Forest Sheoke and no one opting for Sandpiper Fig.
- The most popular Shrub was Coffee Bush with over 70% of respondents choosing it and the remainder selecting Narrow leaved Geebung with no one opting for Large Leaf Hop Bush.
- The most popular options for ground cover were False Bracken and Kangaroo Grass, each chosen by 40% of respondents with the remaining 20% opting for Variable Leaved Goodenia.
- The ETTT Alliance received several suggestions to plant creeper plant/vines along the noise barriers to assist with the proposed visual impact mitigation but also graffiti management. Following consultation with Sydney Trains creepers or vines cannot be planted along the noise walls due to the adverse effect on the longevity of the noise barriers and reducing visibility during maintenance inspections.

### Look and feel of NB02 – Wongala Crescent noise barrier

- The most popular colour choice for the noise barrier was Mist Green with over 72% of respondents choosing it.
- The most popular tree was Blueberry Ash with over 71% of respondents choosing it and the remainder selecting Forest Sheoke and Sandpiper Fig.
- The most popular Shrub was the Narrow Leaved Geebung with 60% of respondents choosing it and the remainder selecting Large Leaf Hop Bush and Coffee Bush.
- The most popular ground cover was False Bracken with over 42% of respondents choosing it with the remainder closely split between Variable Leaved Goodenia and Kangaroo Grass.
- Residents encouraged as much vegetation planting as possible and several made suggestions about planting creeper plants/vines to deter graffiti.
- The ETTT Alliance received several suggestions to plant creeper plant/vines along the noise barriers to assist with the proposed visual impact mitigation but also graffiti management. Following consultation with Sydney Trains creepers or vines cannot be planted along the noise walls due to the adverse effect on the longevity of the noise barriers and reducing visibility during maintenance inspections.

### Look and feel of NB03 – Noise barrier south of Pennant Hills Road

- The most popular colour choice for the noise barrier was Mist Green with 90% of respondents choosing it.
- No vegetation is proposed for NBO3 because only minor trimming and clearing of existing vegetation is required for its construction.
- The ETTT Alliance received several suggestions to plant creeper plant/vines along the noise barriers to assist with the proposed visual impact mitigation but also graffiti management. Following consultation with Sydney Trains creepers or vines cannot be planted along the noise walls due to the adverse effect on the longevity of the noise barriers and reducing visibility during maintenance inspections.
- One resident objected to the construction of noise barriers altogether.

### Additional noise mitigation

- Some respondents queried the extent and height of noise barriers requesting they be either extended in length and/or height. Noise barriers are only considered at locations where properties that are predicted to exceed EPA guideline trigger levels as a result of the project are clustered closely together and noise reduction benefits can be maximised. Once these properties were identified, various mitigation measures, including noise barriers were assessed to determine the benefits they might provide. Where noticeable benefits are predicted, noise barriers were assessed for acoustic and cost effectiveness. The extent (location and height) of noise barriers that will be constructed are based on the findings outlined in the ONVR which was approved by Department of Planning and Environment in December 2014. As such, height and extent of noise barriers cannot be changed.

### Additional planting and graffiti management

- Some additional requests for planting were also made including along the rail embankment opposite Azalea Grove and along Wongala Crescent but these opportunities are limited by the available space and proximity of nearby rail infrastructure.
- Some respondents suggested that anti-graffiti coating should be applied to the noise barriers. The ETTT Project has to comply with the Sydney Trains' (asset owner) requirements when it comes to graffiti management. Sydney Trains' approach to removal of graffiti is to paint over the graffiti. An anti-graffiti coating will only be provided to hard surfaces in public areas. In these areas good access is available for maintenance staff to remove graffiti rather than to paint over it. However, an anti-graffiti coating is not being applied within the rail corridor as suggested by some members of the community. This is due to the need to use high pressure water blast to remove graffiti on top of an anti-graffiti coating. This is impractical within the rail corridor where access for equipment is extremely limited. Therefore painting using a similar colour to the substrate has been found by the Sydney Trains corridor maintainers to be the preferred and more effective solution.



## 1.8 Ongoing and future communications

The ETTT Project team at ETTT will continue to communicate with local residents and stakeholder groups through:

- Monthly notifications
- Regular updates on the project website
- Letter box drops
- Individual meeting and briefings
- Phone calls

Briefings with Hornsby Shire Council and local Civic Trusts will continue at appropriate intervals until project completion. The wider community will be notified about the chosen noise barrier colour and revegetation options.

This page has been intentionally left blank



## 2. Urban and landscape design objectives and principles for the noise barriers

### 2.1 Relationship to UDLP Vision

The vision statement in the approved UDLP is:

*“To deliver the ETTT Project safely and develop a design that fits in sensitively within the existing urban environment and makes a positive contribution to the rail users and community.”*

As significant elements of the project, the noise barriers have been designed to embrace the project’s overall vision statement.

### 2.2 Urban design objectives

The design objectives which have been established specifically for the noise barriers are to:

- Ensure design delivers required acoustic performance
- Minimise visual impacts on neighbours
- Make the barriers visually recessive, so that they blend into their context as much as possible
- Relate barrier design to context - best fit within the existing landscape
- Deliver high-quality aesthetic outcomes on both sides of barriers
- Achieve environmental sustainability through:
  - low energy use in materials, manufacture, transport and installation
  - durability / longevity
  - endemic plant species
- Minimise and manage anti-social behaviour (graffiti)

The barrier design objectives have been derived from and are fully compatible with the overall urban design objectives for the project.

### 2.3 Urban design principles

The following urban design principles have been developed to ensure that the objectives set out above are achieved:

- Where variable topography requires that barrier tops are stepped, design stepping carefully to avoid a haphazard and expedient appearance
- No capping (preference) or capping with minimal appearance to tops of barriers
- Posts may be exposed on rail side
- Posts may be exposed on neighbours’ side if design of fixing clips/ angles ensure good aesthetic outcomes are achieved
- Barrier type must be environmentally sustainable – low embodied energy, low construction energy consumption, minimal maintenance, long life
- New landscaping should predominantly comprise endemic plants
- Integrate landscape treatment into barrier design when replanting disturbed areas
- Use simple, elegant design, mid to dark colour palette and planting to make barriers recede visually - avoid visually assertive surface treatments (graphic patterns, abstract images, bright colours, relief carving) which would draw attention to the barriers

The ETTT noise barrier design takes account of relevant design standards and guidelines such as the NSW Sustainable Design Guidelines for Rail (v2.0, TfNSW, 2011), RMS Noise Wall Design Guidelines (RMS, February 2007), Crime Prevention Through Environmental Design Principles (Department of Urban Affairs and Planning, 2001) and relevant Agency and Council design standards.

This page has been intentionally left blank



# 3. Concept Design

## 3.1 Acoustic engineering parameters: barrier locations and heights

The locations where noise barriers are required and their minimum heights to achieve the degree of noise attenuation specified for the project have been determined by the ETTT Project's approved Operational Noise and Vibration Review.

Three barriers are required:

1. Noise Barrier 01: On the up side, between Copeland Road and Chapman Avenue bridges at Beecroft Station.
2. Noise Barrier 02: On the down side, between approximately 49 and 107 Wongala Crescent, Pennant Hills.
3. Noise Barrier 03: On the up side, between approximately Hampden Road and 15 Cassia Grove, Pennant Hills.

The locations and extents of the barriers are illustrated in the aerial view at Figure 3-1.

Numerical data is summarised in the following table:

Barrier	Overall Length	Minimum Height (metres)	Maximum Height (metres)
Noise Barrier 01	461.2	1.5m	5.5m
Noise Barrier 02	528.0	2.5m	7.5m
Noise Barrier 03	386.3	5.0m	5.0m

All barriers are located wholly within the rail corridor. In addition to acoustic requirements, the exact location of a barrier at any given point is the product of a number of considerations, including:

- Space available after accommodation of the new third track, utilities, services, overhead wiring masts, station platforms, drainage and the like
- Noise mitigating opportunities provided by existing or engineered features within the corridor (e.g. locating noise barriers at the tops of cuttings)
- Minimisation of vegetation removal
- Structural requirements
- Construction limitations

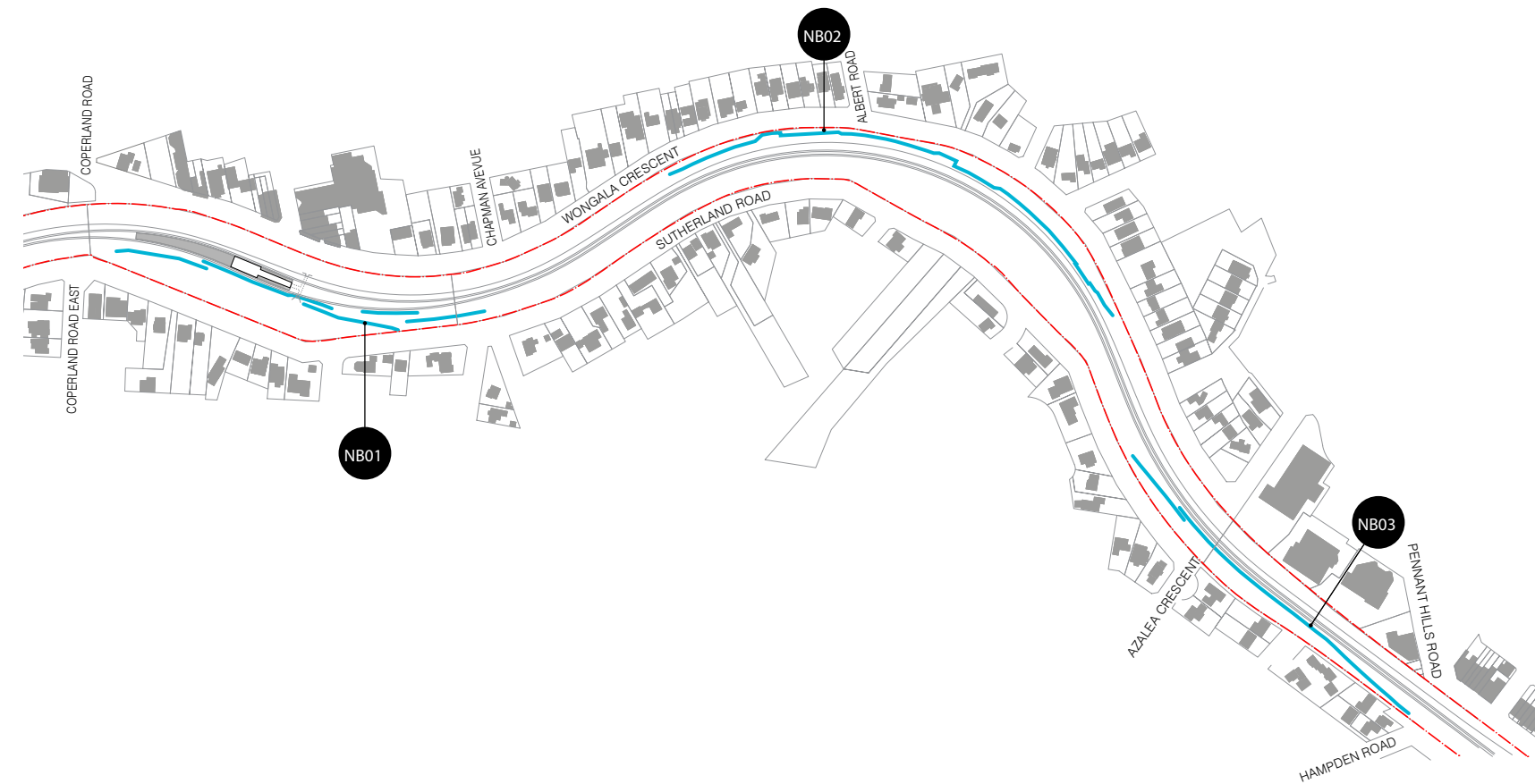

Figure 3-1 Overall Noise Barrier Location Plan

## 3.2 Barrier type

The noise barriers will be made from aerated concrete panels. This is an effective material to reduce noise impacts as it is a solid barrier that interrupts the path of noise.

The panels will be installed horizontally between vertical steel posts. Each panel will vary between 3 and 6 metres in length and between 0.3 and 0.6 metres in height. The panels will be approximately 150 millimetres thick.

The top of the noise barriers will be stepped to accommodate the changes in ground level.

### Texture

Finish options considered for the noise barrier panel included:

- A smooth plain surface;
- A textured concrete surface;

In responding to the existing natural landscaped character of the barriers' context, a textured/patterned or graphic surface finish would not be the most appropriate response. Such treatments tend to draw attention to the barriers. A smooth plain concrete finish provides a more visually neutral solution and a more subtle backdrop to the existing and replacement vegetation.

### Colour

The three colour options were chosen for the barrier allow them to blend into the existing environment. These colours are also used by Sydney Trains for maintenance, ensuring a consistent colour will be used after the project is completed. Based on community feedback, all 3 noise barriers will be painted Mist Green.

The three colour options were:



Mist Green

Cola (Dark Brown)

Smoke Ash

### Graffiti

The ETTT Project aims to deter graffiti by minimising the removal of vegetation and maximising revegetation of the area in front of the noise barriers post construction. The maintenance strategy being adopted by ETTT Project for the removal of graffiti is to re-paint damaged panels. This is in line with Sydney Trains graffiti management guidelines.

The ETTT Alliance received several suggestions to plant creeper plant/vines along the noise barriers to assist with the proposed visual impact mitigation but also graffiti management. Following consultation with Sydney Trains creepers or vines cannot be planted along the noise walls due to the adverse effect on the longevity of the noise barriers and reducing visibility during maintenance inspections.

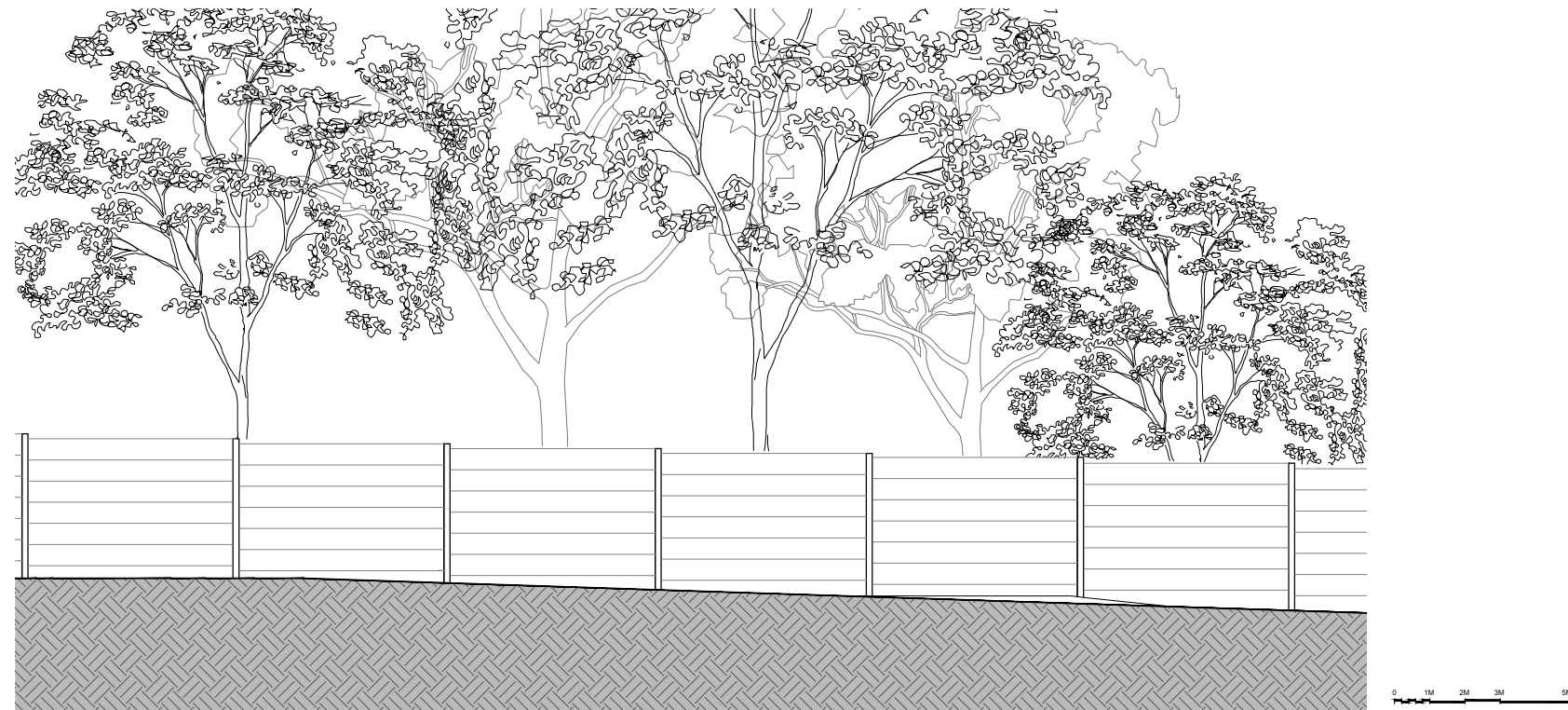

Figure 3-2 Proposed Noise Wall Design: Elevation - Railway Side

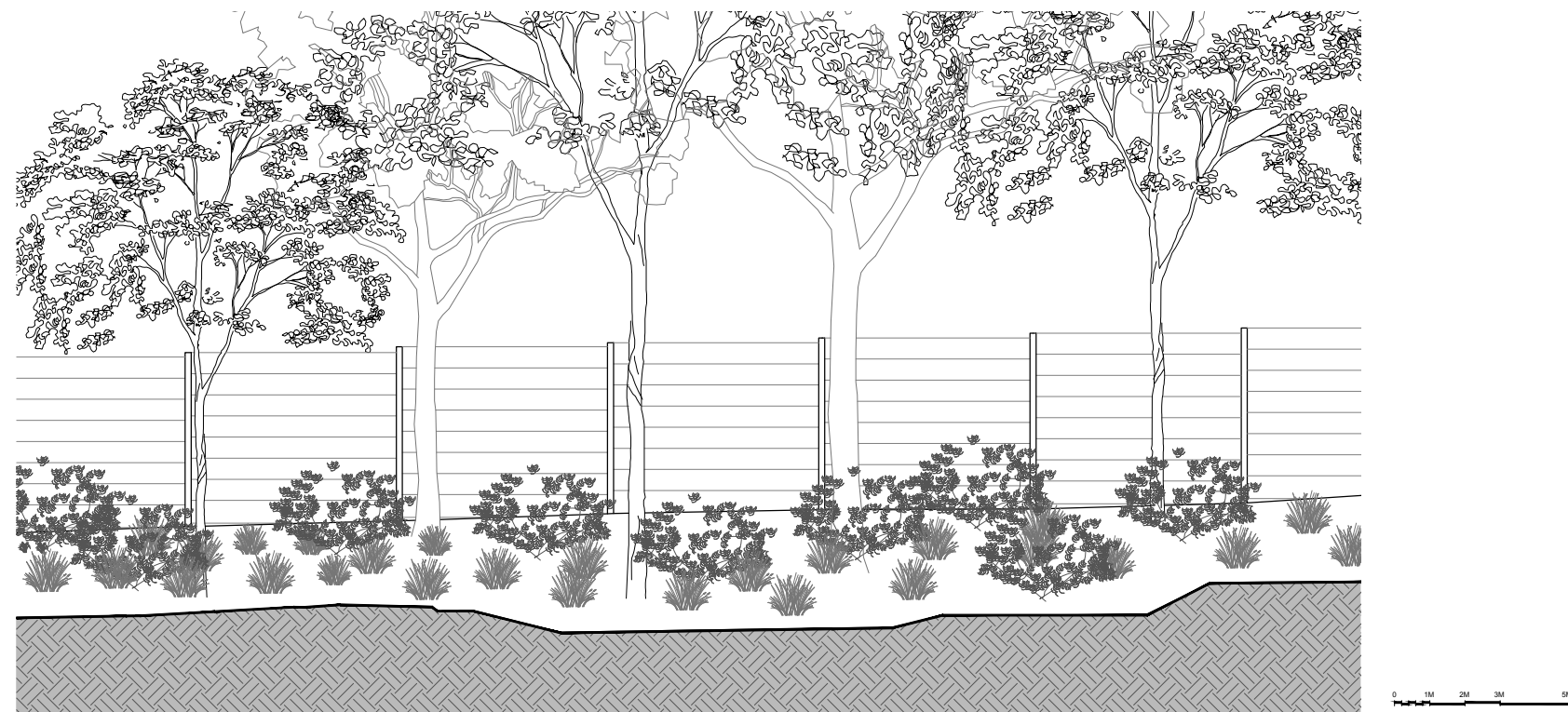

Figure 3-3 Proposed Noise Wall Design: Elevation - Residential Side



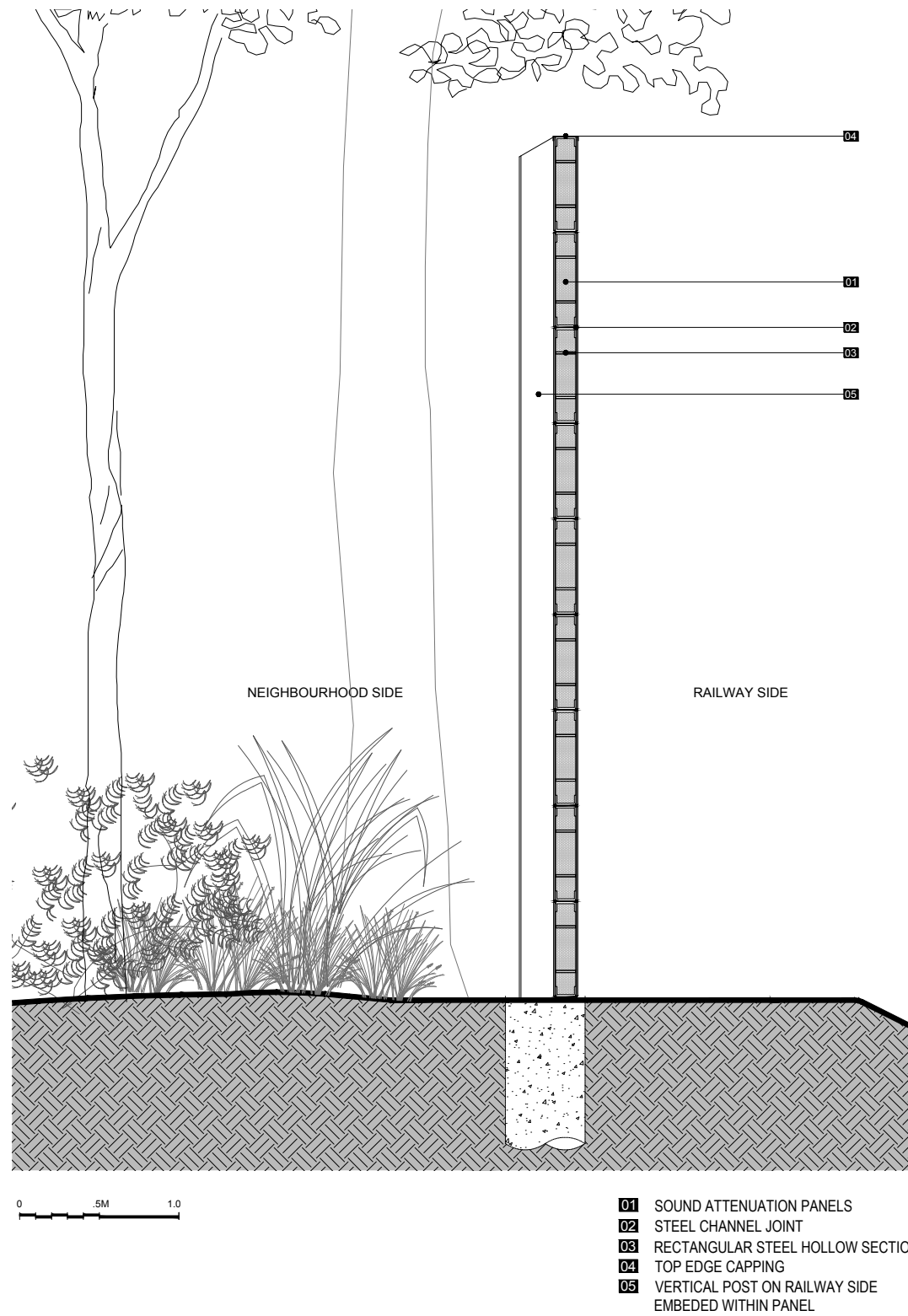

Figure 3-4 Proposed Noise Wall Design: Section

- 01 SOUND ATTENUATION PANELS
- 02 STEEL CHANNEL JOINT
- 03 RECTANGULAR STEEL HOLLOW SECTION
- 04 TOP EDGE CAPPING
- 05 VERTICAL POST ON RAILWAY SIDE EMBEDDED WITHIN PANEL

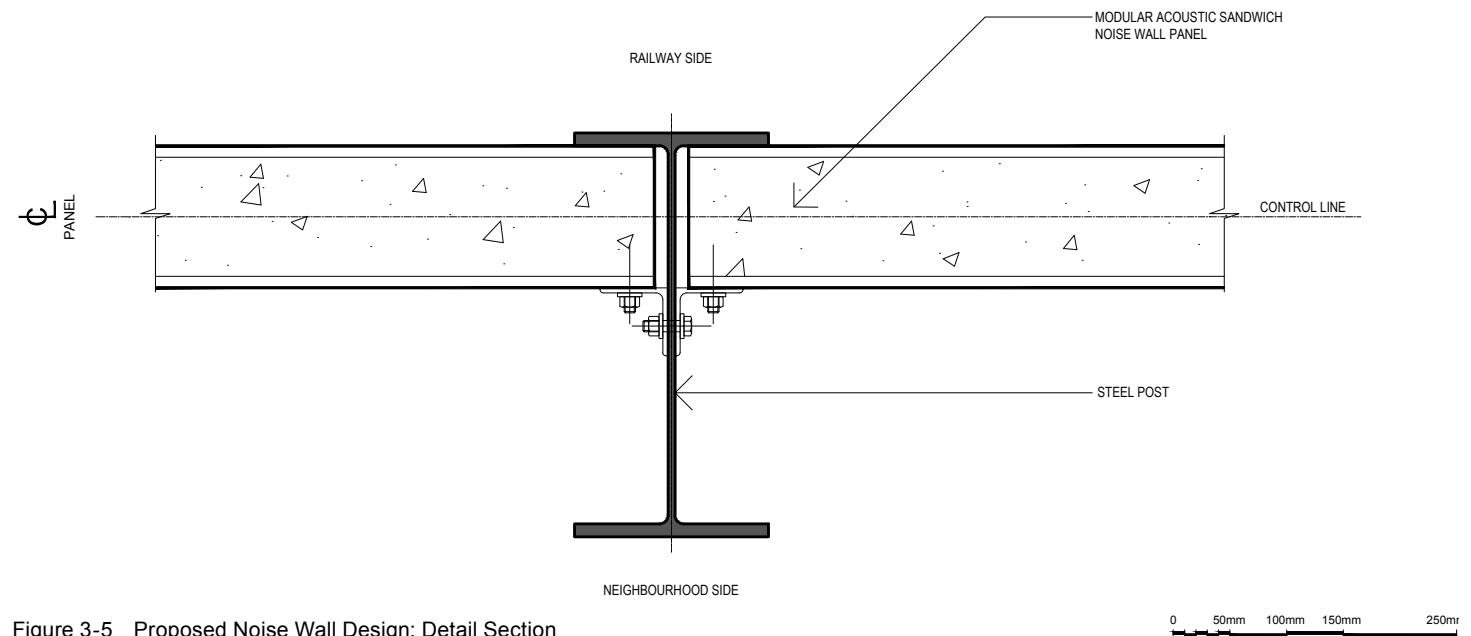

Figure 3-5 Proposed Noise Wall Design: Detail Section

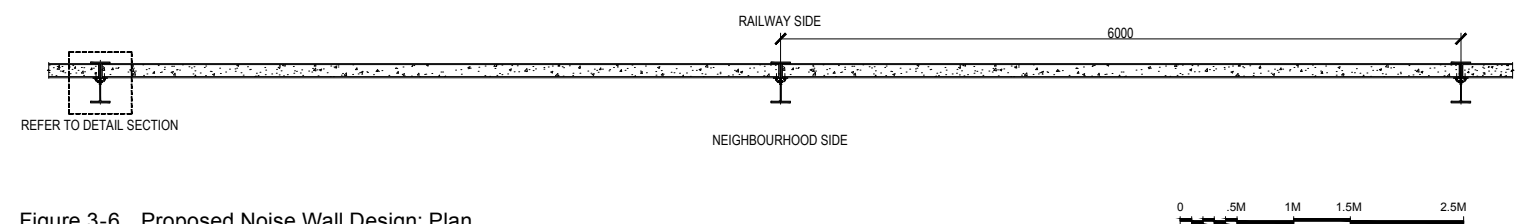

Figure 3-6 Proposed Noise Wall Design: Plan

**Note:**

1. Noise barrier panels to be placed against neighbourhood side of steel posts (opposite to that shown on this drawing) at NB01-P04 and NB02-P03

### 3.3 Landscape design

The overall intent of the proposed landscape is to replace areas of existing vegetation which will require removal to construct the barriers. Replanting will be done with endemic species. Further opportunities, where possible, within the corridor are limited because of rail system equipment requirements, maintenance access and safety considerations.

All landscape works on the ETTT Project must be carried out in accordance with:

- Sydney Trains Revegetation Guide – EMS-09-GD-0074
- Sydney Trains Revegetation Technical Specification – EMS-09- TP-0066
- Sydney Trains Bush Regeneration Technical Specification Template – EMS- 09-TP-64.

Landscaping must be installed to comply with:

- Sydney Trains Security Standard RSS-001
- AS 4419 'Soils for Landscaping and Garden use'
- AS 4454 'Composts Soil Conditioners and Mulches'
- Sydney Trains Crime Prevention Through Environmental Design
- Sydney Trains Environmental Management Standards – EMS- 09-GD-0066, 0067, 0068, 0074 and 0095.

It is expected that installation of the landscape works will use hydro-mulching and tubestock planting. Maintenance requirements are summarised in Table 3-1. **Community preferences**

#### Noise Barrier 1 - along Sutherland Road

- In line with community feedback received the majority of the trees that will be planted along this barrier will be Blueberry Ash with some Forest Sheokes and no Sandpaper Figs. Coffee Bush will be the predominantly planted shrub with some Narrow Leaved Geebung and no Large Leaf Hop Bush. In term of ground cover preference will be given to planting False Bracken, Kangaroo Grass and some Variable leaved Goodenia.

#### Noise Barrier 2 - along Wongala Crescent

- In line with community feedback received the majority of the trees that will be planted along this barrier will be Blueberry Ash with some Forest Sheokes and Sandpaper Figs. Narrow Leave Geebung will be the predominantly planted shrub with some Narrow Leaved Geebung and no Coffee Bush. In terms of ground cover preference will be given to planting False Bracken and some Variable leaved Goodenia and Kangaroo Grass.

Table 3-1 Summary table of maintenance requirements

Maintenance Actions	Timeframes/Frequency			Notes
	Weekly	Monthly	As Required	
<b>All areas</b>				
1. Pruning of Vegetation for Safety				
2. Noxious Weed Control				
3. Rubbish Removal				
4. Auditing and Reporting				
<b>Vegetation areas (Hydro-mulching)</b>				
1. Weeding				Use biodegradable herbicide only. Replace landscape plants damaged or killed by herbicide.
2. Herbicide Spraying				
3. Remove Dead/Dying Vegetation				
4. Replacement Hydro-mulching	Watering			When possible, apply seeding during optimum seasonal conditions.
<b>Tubestock areas</b>				
1. Weeding				If required, use biodegradable herbicide only. Replace landscape plants damaged or killed by herbicide.
2. Disease and Insect Control				Spraying must only occur on windless days.
3. Mulching				Every two years.
4. Removal of Dead / Dying Plant Material				
5. Replacement Plantings				Within 28 days of detection.
	Watering			Water replacement plantings for 12 weeks.
6. Timber Stakes				Check and repair timber stakes as required. Final removal at 12 months after planting.
7. Fertilising and Pruning				Fertilise annually in spring.



Table 3-2 ETTT Recommended Plant List for NB01 & NB02 derived from the Blue Gum High Forest Ecological Community

Botanical Name	Common Name	Approx. Mature Height
<b>TREES</b>		
<i>Allocasuarina torulosa</i>	Forest Sheoke	10m
<i>Elaeocarpus reticulatus</i>	Blueberry Ash	8m
<i>Ficus coronata</i>	Sandpaper Fig	8m
<b>SHRUBS</b>		
<i>Breynia oblongifolia</i>	Coffee Bush	3m
<i>Persoonia linearis</i>	Narrow-leaved Geebung	4m
<i>Dodonaea triquetra</i>	Large leaf Hop Bush	2.5m
<b>SMALL SHRUBS/GROUNDCOVERS/GRASSES</b>		
Botanical Name	Common Name	Approx. Mature Height
<i>Goodenia heterophylla</i>	Variable-leaved Goodenia	400mm
<i>Calochlaena dubia</i>	False Bracken	1.2m
<i>Themeda australis</i>	Kangaroo Grass	750mm



*Elaeocarpus reticulatus*  
BLUEBERRY ASH



*Breynia oblongifolia*  
COFFEE BUSH



*Calochlaena dubia*  
FALSE BRACKEN



*Ficus coronata*  
SANDPAPER FIG



*Allocasuarina torulosa*  
FOREST SHEOKE



*Dodonaea triquetra*  
LARGE LEAF HOP BUSH



*Goodenia heterophylla* eglan  
VARIABLE-LEAVED GOODENIA



*Persoonia linearis*  
NARROW-LEAVED GEEBUNG



*Themeda australis*  
KANGAROO GRASS



### 3.4 NB01: Along Sutherland Road near Beecroft Station

Refer Figure 3-7 to Figure 3-14.

The ONVR proposed a low height noise barrier inside the rail corridor between Copeland Road and the Chapman Avenue Bridge. Further design and investigations confirmed that the low height barrier could not be built due to space constraints and safety within the rail corridor.

To provide mitigation for the properties identified in the ONVR, a noise barrier ranging between 1.5 and 5.5 metres high will be built in five overlapping sections on the eastern side of the rail corridor (Sutherland Road side) between Copeland Road and Chapman Avenue. The barrier will provide the same acoustic benefit as the originally proposed barrier. At the existing pedestrian underpass accessing the station platform, the barrier takes the form of an upward extension of the existing brick portal.

The construction of this noise barrier requires the removal of some existing vegetation north of the pedestrian underpass. Vegetation within the subject site includes a patch Sydney Turpentine-Ironbark Forest. This patch has a canopy including species such as *Eucalyptus paniculata* (Grey Ironbark), *Eucalyptus pilularis* (Blackbutt), *Eucalyptus punctata* (Grey Gum), *Eucalyptus resinifera* (Red Mahogany) and *Eucalyptus acmenoides* (White Mahogany). Areas to the north of the Turpentine Ironbark Forest consist of degraded patches of Blue Gum High Forest. This includes some areas within the rail corridor which predominately consist of small-tree sized individuals of *Eucalyptus paniculata*, growing over juvenile shrub sized regrowth of this species, and exotic and non-endemic species including *Acacia podalyriifolia* (Queensland Silver Wattle), *Cytisus scoparius* and the grass *Pennisetum clandestinum*.

The proposed noise barrier installation works will require removal of 0.26 ha of vegetation; including 0.042 ha of Blue Gum High Forest (TSC Act) and 0.038 ha of Sydney Turpentine-Ironbark Forest (TSC Act). As shown on Figure 3-10, new landscaping will be planted on the neighbourhood (off-rail) side of section 3 of the barrier after it has been installed. Planting in front of section 1 will not be possible because there is a maintenance worker access track against the barrier and immediately beyond is a public carpark. Planting in front of the other sections of this noise barrier cannot be provided because there are vehicular maintenance access tracks alongside them.

The UDLP (June 2014) does not propose any changes to the existing landscaping on the east side of the station (whereas extensive planting including species unique to this location is specified for the west side). Consistent with this approach, the new planting proposed in association with NB01 is consistent with the existing mixed native bushland character of the open space adjacent to the rail corridor.

The proposed species are drawn from the relevant ecological community, namely, the *Blue Gum High Forest Ecological Community* and are in line with the community feedback. Refer Section 3.3.1.

#### 3.4.1 Shadow impacts (shadow diagrams)

A computer generated analysis of shadows which the proposed barriers will cast has been undertaken to assess potential impacts (Figure 3-7 to Figure 3-9).

Shadows are shown at the winter solstice (21 June), the time of the year when sunlight is least available and air temperatures are low. In general, only topography and buildings are taken into account.

Shadows cast by the proposed barriers most typically fall within the rail corridor, with a lesser degree of overshadowing of roadways. Private properties are not affected.



Figure 3-7 Shadow Diagram 9AM June 21

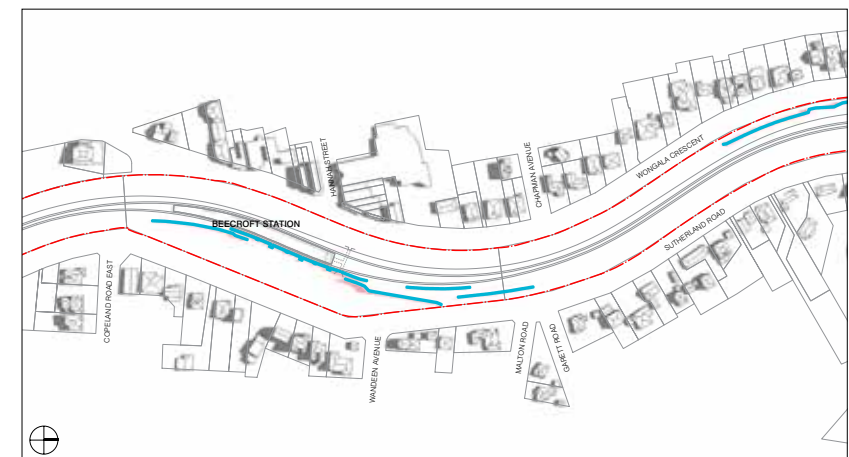

Figure 3-8 Shadow Diagram 12PM June 21

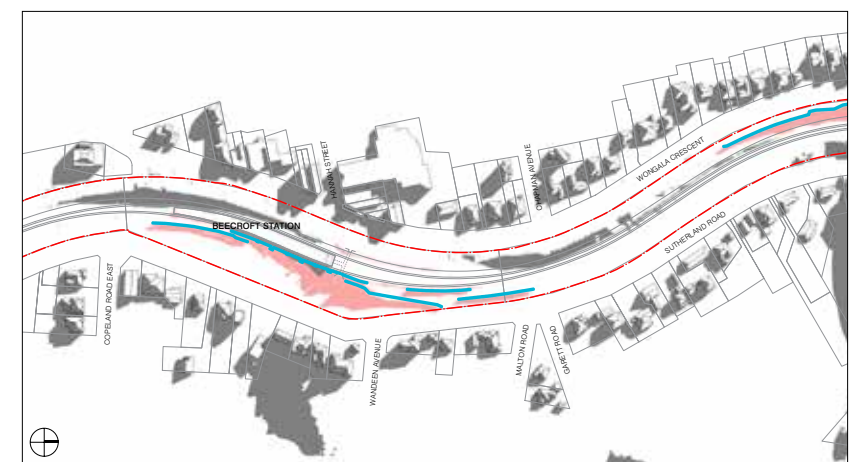



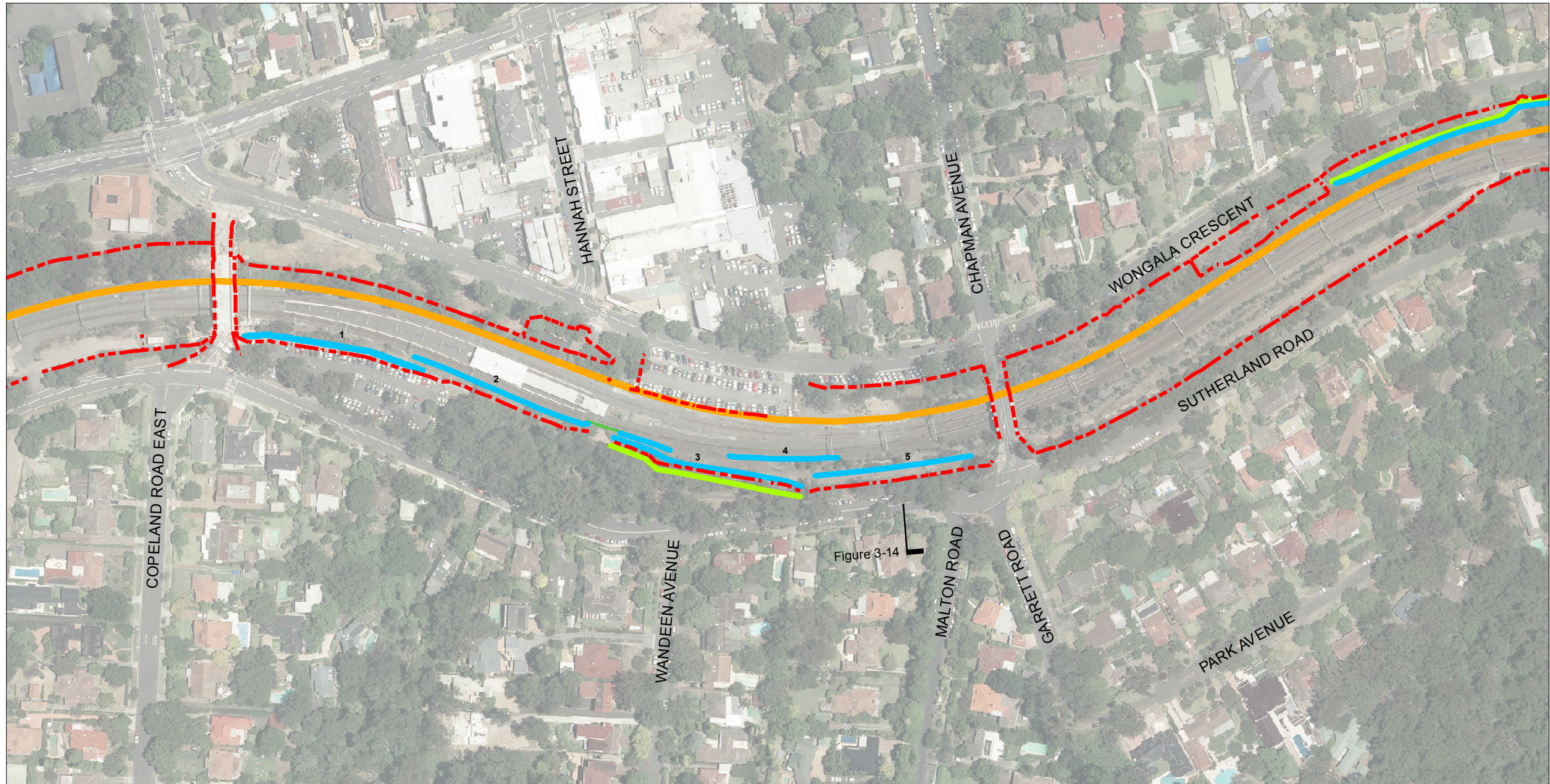

Figure 3-9 Shadow Diagram 3PM June 21

-  PROPERTY BOUNDARY
-  BUILDINGS
-  SHADOWS FROM BUILDINGS/ TOPOGRAPHY
-  SHADOWS FROM NOISE BARRIER





- NOISE BARRIER
- BOUNDARY FENCE
- PROPERTY BOUNDARY
- NEW THIRD TRACK
- AREAS WHERE LANDSCAPING / REPLANTING IS PROPOSED
- 2 BARRIER SECTION



Figure 3-10 NB01: Location and Landscaping Plan



### 3.4.2 Visual impacts (Photomontages)

A comprehensive series of digital photomontages has been prepared to understand the visual impacts of the proposed barriers (Figure 3-11 to Figure 3-13). These are presented here along with the same image as currently exists prior to construction of the barrier.

The brick wall at this location serves as the noise barrier. Above the wall, a metal palisade fence is required to prevent unauthorised access to the rail corridor.



Existing



Figure 3-11 Photomontage from Sutherland Road at Copeland Road East





Existing



Mist Green - this is the colour chosen by the community



Cola (Dark Brown)



Smoke Ash

Figure 3-12 Photomontage from Sutherland Road near Garret Road





Figure 3-13 Photomontage at Beecroft Station Underpass, east end



Existing

The noise barrier above the pedestrian underpass and around the station precinct will be constructed with bricks to complement the existing heritage appearance





Figure 3-14 Typical cross section view

### 3.5 NB02: Along Wongala Crescent between approximately 49 and 107 Wongala Crescent

Refer Figure 3-15 to Figure 3-22.

#### Noise Barrier Redesign to Minimise Vegetation Clearance

The ONVR identified a noise barrier approximately 660 metres long would be built from 49 Wongala Crescent, Beecroft to 107 Wongala Crescent, Pennant Hills. The ONVR also identified that a large amount of Blue Gum High Forest, an endangered ecological community, would need to be removed to construct the barrier in this area. The project team is constantly looking at ways to minimise impacts on vegetation and has been working on the design of the barrier and the construction methods to minimise impacts on the Blue Gum High Forest ecological community. As a result of this process the project team will be able to construct the barrier in a location that will result in the majority of vegetation in this area being retained.

The barrier will be constructed closer to the rail corridor boundary and the length reduced by approximately 100 metres at the northern end to save a community of Blue Gum High Forest (see map below).

Due to the shortening of the noise barriers 5 properties which were previously behind the wall will now be offered at property acoustic treatment. The Project team will contact these properties in due course.

The height of the barrier identified in the ONVR has not been changed and will vary in height between 2.5 metres at the top of the cuttings and up to 7.5 metres at the low point of gullies to accommodate the varying topography and the acoustic properties of the noise barrier are maintained.

Vegetation within the corridor in the vicinity of this noise barrier consists of Blue Gum High Forest in two conditions. One condition of the community has a predominately exotic understorey and ground layer, and is highly degraded. It makes up the majority of the community within this area. The other condition of the community has a predominately native understorey and ground layer, and is the northern extent of the vegetation within NB02. The degraded areas of Blue Gum High Forest in this area have a tall canopy of remnant trees, predominately of *Eucalyptus saligna*. There are scattered occurrences of other remnant tree species including *Angophora costata*, *Eucalyptus pilularis* (Blackbutt), *Angophora floribunda* (Rough-barked Apple) and *Eucalyptus paniculata*. The northern extent of Blue Gum High Forest within NB02 is relatively weed free with the only scattered occurrences of *Lantana camara*, *Ligustrum lucidum*, *Schefflera actinophylla* (Umbrella Tree) and *Ehrharta erecta*. Endemic, native species are dominant in all strata, and a reasonably diverse array of species is present in the patch. Canopy trees consist of tall, remnant individuals of *Eucalyptus saligna*, *Eucalyptus pilularis* and *Eucalyptus paniculata*.

The proposed works will impact on 0.315 ha of vegetation within the subject site, with only 0.024 ha of canopy and associated understorey being completely removed, and 0.008 ha of canopy being trimmed. The remaining 0.283 ha of vegetation consists of predominately exotic ground layer vegetation occurring within the rail corridor in areas that have undergone earthworks previously during rail works, and some areas of exotic woody vegetation. A total of 0.032 ha of Blue-Gum High Forest (TSC Act only) canopy will be impacted as a result of the proposed NB02 works of which 0.024 ha of this community is to be cleared, with the remaining 0.008 ha trimmed only.

New landscaping will generally be planted along the neighbourhood (off-rail) side of the barrier where existing vegetation must be removed to allow its construction (refer Figure 3-18). This will occur for approximately two thirds of the total barrier length. Where new planting is not proposed, the barrier is located well inside the rail corridor boundary so that substantial amounts of existing vegetation will remain between the barrier and Wongala Crescent or the pedestrian track in the gully.





The proposed landscaping is sympathetic to existing bushland character of the verge between Wongala Crescent and the rail line. It will draw on species from the relevant ecological community, namely, the *Blue Gum High Forest Ecological Community* and are in line with the community feedback. Refer Section 3.3.1.

#### Shadow impacts (shadow diagrams)

A computer generated analysis of shadows which the proposed barriers will cast has been undertaken to assess potential impacts (Figure 3-15 to Figure 3-17).

Shadows are shown at the winter solstice (21 June), the time of the year when sunlight is least available and air temperatures are low. In general, only topography and buildings are taken into account. The exception is NB03 at 3.00pm, as discussed in 3.6.1.

Shadows cast by the proposed barriers most typically fall within the rail corridor, with a lesser degree of overshadowing of roadways. Private properties are not affected.

-  PROPERTY BOUNDARY
-  BUILDINGS
-  SHADOWS FROM BUILDINGS/ TOPOGRAPHY
-  SHADOWS FROM NOISE BARRIER

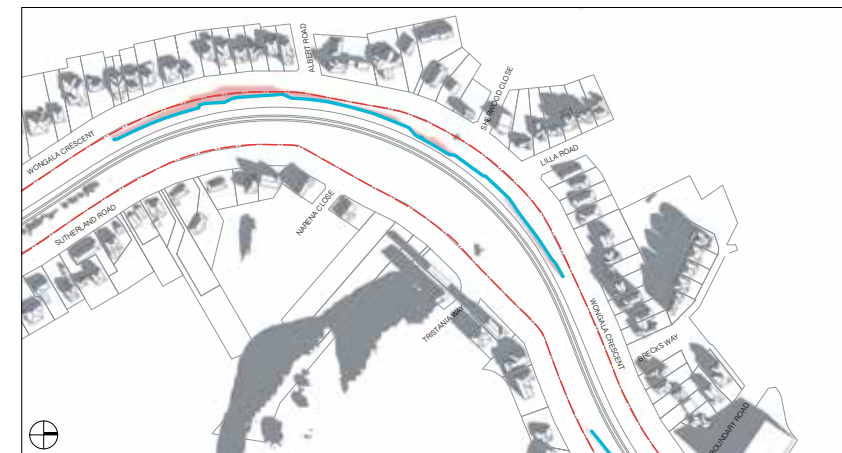

Figure 3-15 Shadow Diagram 9AM June 21

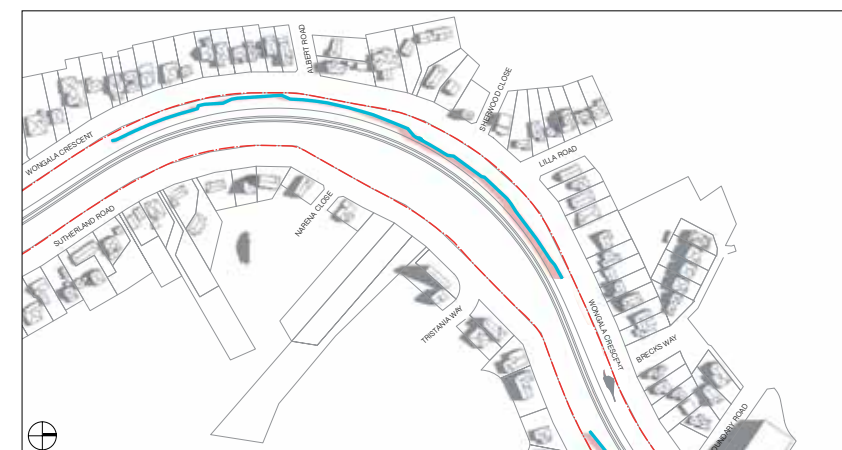

Figure 3-16 Shadow Diagram 12PM June 21

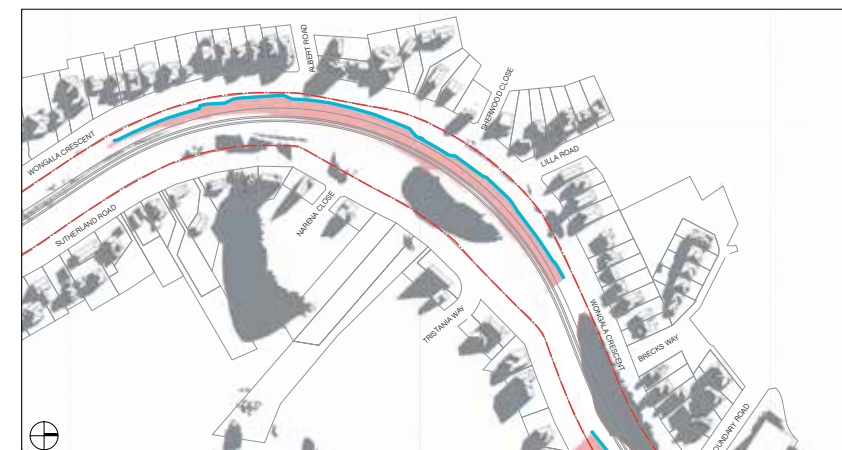

Figure 3-17 Shadow Diagram 3PM June 21



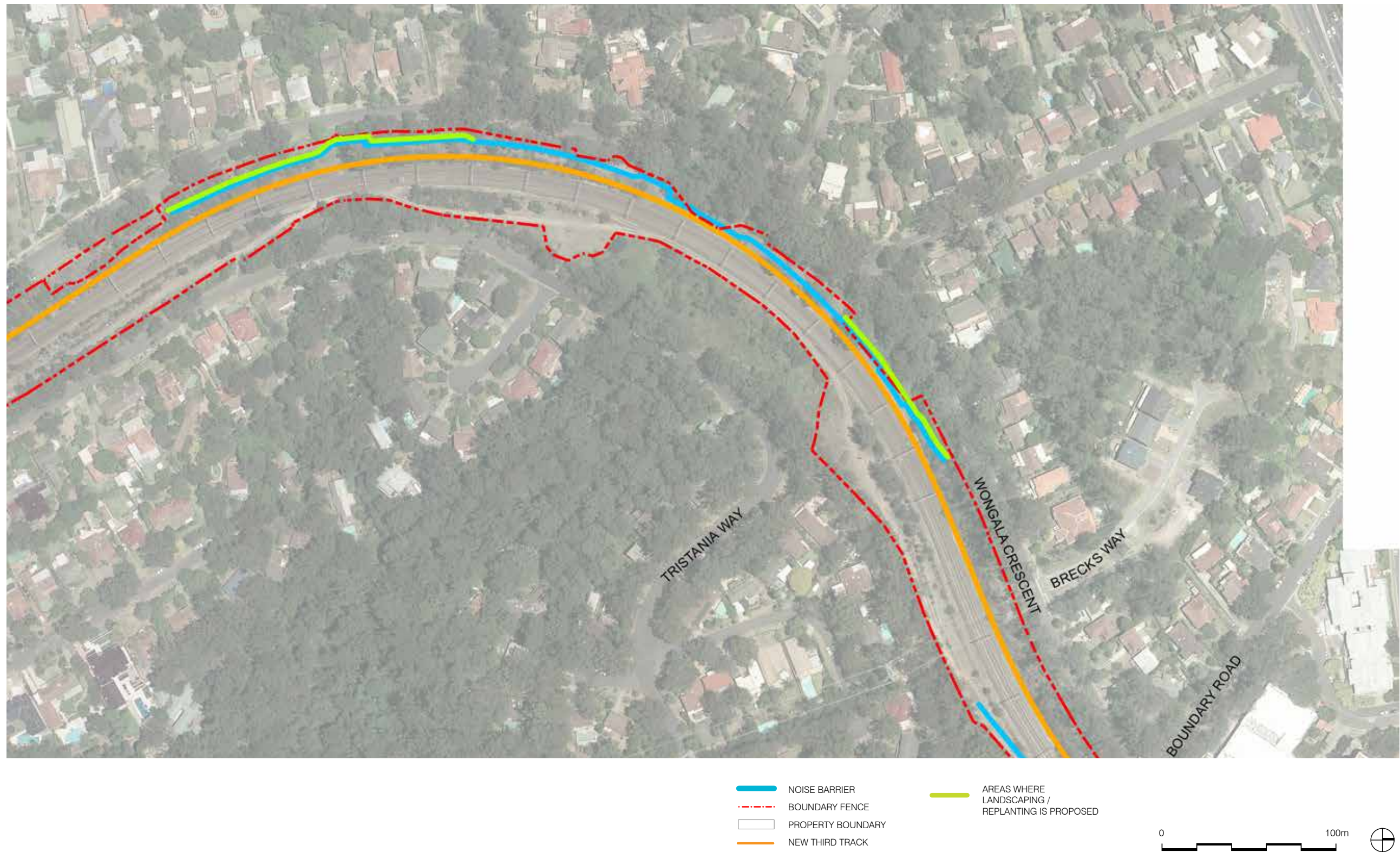

Figure 3-18 NB02: Location and Landscaping Plan



### 3.5.1 Visual impacts (Photomontages)

A comprehensive series of digital photomontages has been prepared to understand the visual impacts of the proposed barriers (Figure 3-19 to Figure 3-21). These are presented here along with the same image as currently exists prior to construction of the barrier.



Existing



Mist Green - this is the colour chosen by the community



Cola (Dark Brown)



Smoke Ash

Figure 3-19 Photomontage opposite 57 Wongala Crescent





Existing



Mist Green - this is the colour chosen by the community



Cola (Dark Brown)



Smoke Ash

Figure 3-20 Photomontage opposite 67 Wongala Crescent





Existing



Mist Green - this is the colour chosen by the community



Cola (Dark Brown)



Smoke Ash

Figure 3-21 Photomontage opposite 107 Wongala Crescent





Figure 3-22 Typical cross section view

### 3.6 NB03: South of Pennant Hills Road

Refer Figure 3-23 to Figure 3-29.

NB03 is located on the eastern side of the rail corridor between approximately Hampden Road and 15 Cassia Grove, Pennant Hills. For the most part the noise barrier is positioned at rail level on top of the substantial existing embankment. At its northern end, the barrier is to be constructed along the top of the existing cutting. Two breaks are required to ensure the continued functioning of the existing maintenance vehicle track which runs alongside the rail lines in this location. At these gaps the wall ends overlap sufficiently to ensure the necessary level of acoustic performance is maintained.

The neighbourhood (off-rail) side of this noise barrier is heavily vegetated along virtually its entire length. The vehicular maintenance access track noted above runs alongside the full length of the barrier, so that it will not be possible to plant new landscaping adjacent to the barrier.

#### 3.6.1 Shadow impacts (shadow diagrams)

A computer generated analysis of shadows which the proposed barriers will cast has been undertaken to assess potential impacts (Figure 3-23 to Figure 3-25).

Shadows are shown at the winter solstice (21 June), the time of the year when sunlight is least available and air temperatures are low. In general, only topography and buildings are taken into account. The exception is NB03 at 3.00pm, as discussed below.

Shadows cast by the proposed barriers most typically fall within the rail corridor, with a lesser degree of overshadowing of roadways. Shadowing from the noise walls has almost no additional impact due to the existing shadowing from vegetation and buildings.

In the particular case of NB03 at 3.00pm, the density of mature vegetation is such that it is appropriate to include this as an existing element which casts shadows. Again there is almost no additional impact on private properties from the introduction of NB03.



Figure 3-23 Shadow Diagram 9AM June 21

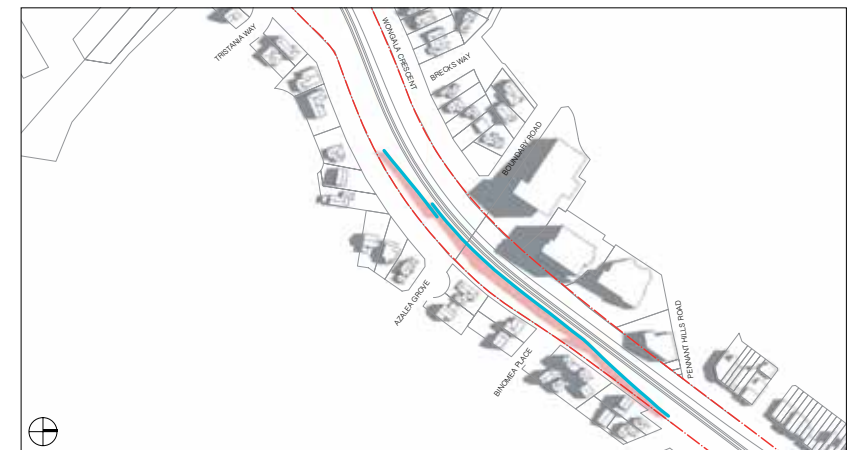

Figure 3-24 Shadow Diagram 12PM June 21

- NOISE BARRIER
- - - RAIL CORRIDOR BOUNDARY
- PROPERTY BOUNDARY
- BUILDINGS
- SHADOWS FROM BUILDINGS/ TOPOGRAPHY
- SHADOWS FROM NOISE BARRIER
- SHADOWS FROM VEGETATION

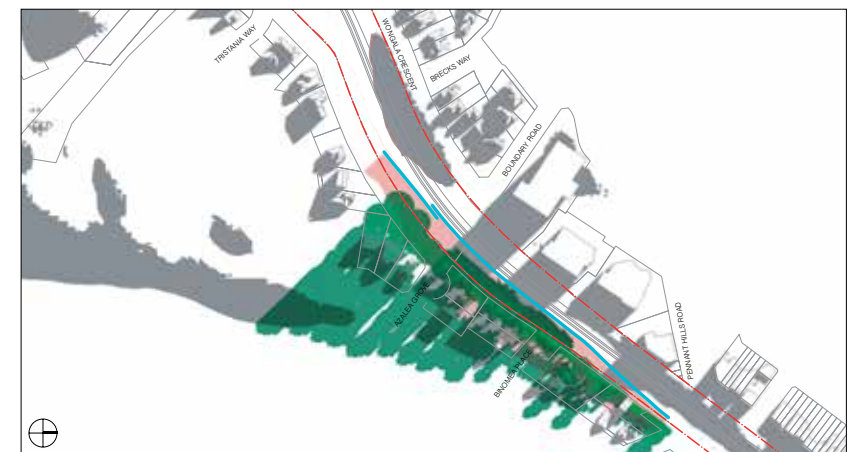

Figure 3-25 Shadow Diagram 3PM June 21



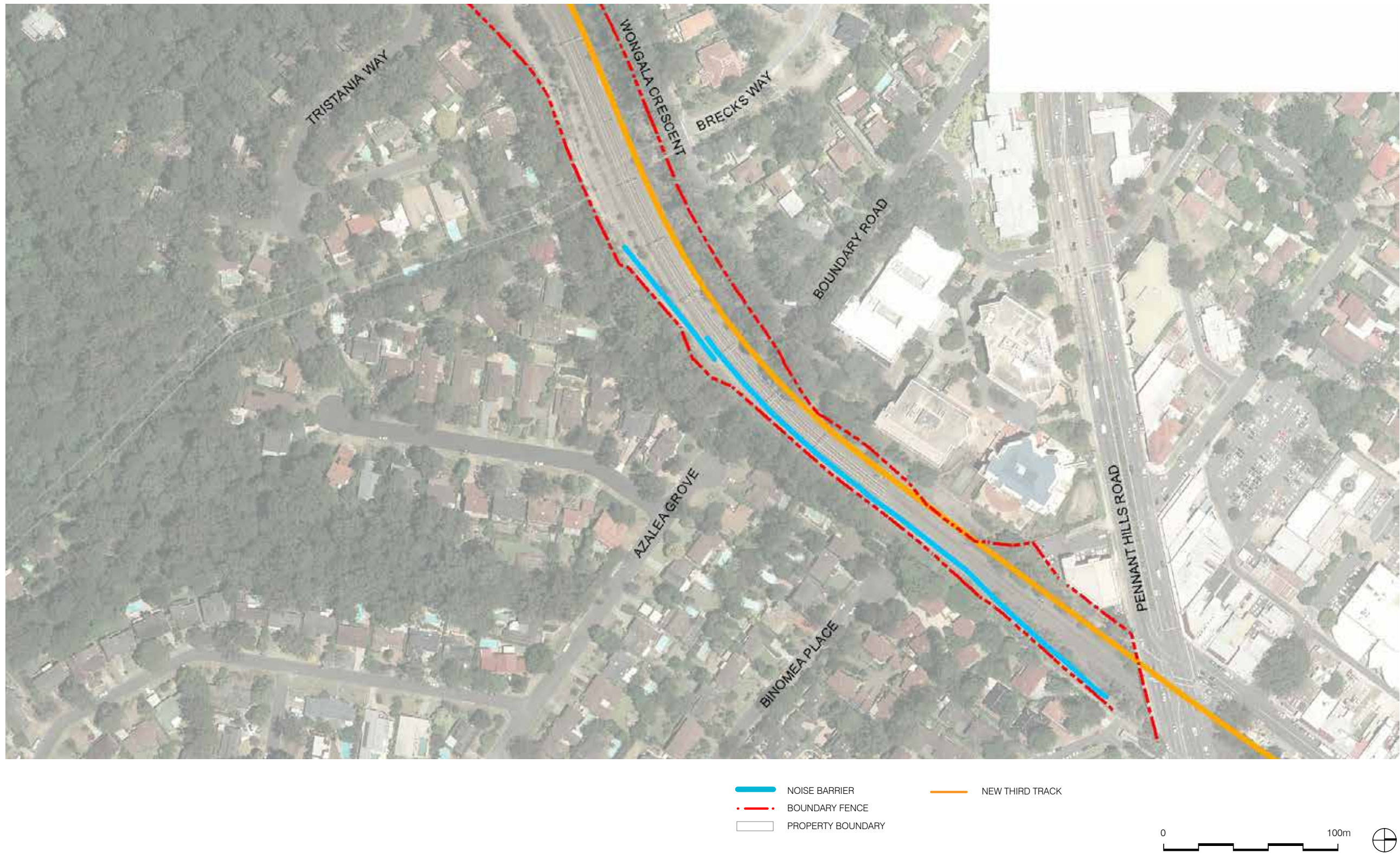

Figure 3-26 NB03: Location and Landscaping Plan



### 3.6.2 Visual impacts (Photomontages)

A comprehensive series of digital photomontages has been prepared to understand the visual impacts of the proposed barriers (Figure 3-27 to Figure 3-28). These are presented here along with the same image as currently exists prior to construction of the barrier.



Existing



Mist Green - this is the colour chosen by the community



Cola (Dark Brown)



Smoke Ash

Figure 3-27 Photomontage at end of Azalea Grove





Existing



Figure 3-28 Photomontage looking east across rail corridor to Binomea Place - **Mist Green is the colour chosen by the community**





Figure 3-29 Typical cross section view



# 4. Contextual analysis and landscape assessment

## 4.1 Contextual analysis

A broad contextual analysis of the whole project area is provided in the ETTT Urban Design and Landscape Plan, June 2014 (UDLP). The following analysis focuses on the immediate surroundings of the proposed noise barriers, extending from Beecroft Station to Pennant Hills Road.

### Landform

The topography is generally variable, with some steep slopes. Notable features include:

- Byles Creek, a deep gully which traverses the corridor at the point where Wongala Crescent is unmade, between Sherwood Close and Albert Road
- Steep falls immediately to the east of the corridor, in the vicinity of Binoemea Place and Azalea Grove, where an existing embankment supports the rail lines

Within the rail corridor there are some significant cuttings, both existing and newly-made for the current ETTT Project, notably:

- An enlarged cutting on the west side of the corridor, just south of the gully noted above
- An existing cutting on the east side of the corridor, adjacent to and just south of Hampden Road

The rail bed rises continuously from Beecroft Station to Pennant Hills Road.



Figure 4-1 Topographic Map

### Land Use

The surrounding area consists almost entirely of detached family dwellings. There is a small school on Wongala Crescent to the north of Chapman Avenue and a group of multi-storey buildings comprising an apartment tower, three office buildings and a telephone exchange just south of Pennant Hills Road on the west side of the corridor. Wongala Crescent runs along most of the western side of this section of the corridor, separating the two. Sutherland Road is located immediately to the east of the corridor, extending from south of Beecroft Station to Tristania Way. From here to Pennant Hills Road, a public footpath replaces the roadway. Several local streets perpendicular to the rail corridor terminate just before this footpath. Refer Figure 4-2.

### Geology and plant communities

The noise barrier section of the corridor comprises black to dark grey shale and laminate. This supports an important Blue Gum High Forest plant community. Weed infestations occur to varying extents throughout.

### Heritage

Most of this section of the corridor lies within Hornsby Shire Council's Beecroft/Cheltenham Heritage Conservation Area. Within the corridor itself, the eastern side is listed by Sydney trains on the s.170 register of the NSW Heritage Act 1977 and by Council in its LEP and the western side is also listed in the LEP. There are no listed individual sites.



Figure 4-2 Land use diagram



## 4.2 Landscape assessment

The landscape character of the immediate context surrounding each proposed barrier is illustrated in the following plans and photographs.

### NB01 (refer Figure 4-3 and associated photographs)

The east side of the rail corridor at Beecroft station contains a commuter car park, dense vegetation of primarily endemic species, the eastern portal of the underpass leading to the station platform and pedestrian pathways leading to this structure. The station itself is visible from the carpark and at various points along the pedestrian pathways. The density of the existing landscape and the local topography obscure views to the rail lines and station from Sutherland Road, except at the car park, where partial views occur.

The native vegetation in this location contrasts markedly with the variety of plant types and planting arrangements which are a feature of the western side of the station precinct.

### NB02 (refer Figure 4-4 and associated photographs)

The context alongside NB02 comprises Wongala Crescent, with detached dwellings in landscaped settings on its western side and dense indigenous vegetation interspersed with “weed” species between the roadway and the rail corridor. At most locations, this zone of dense mature trees and shrubs, which lies partly within the rail corridor and partly outside of it along the eastern verge of Wongala Crescent, effectively screens the existing and proposed rail lines from views from the street. Some existing vegetation has been removed for ETTT construction access, and more will need to be taken away to construct NB02. A notable feature is the deep gully where the roadway is replaced by a steep pathway. At the north end of this precinct, where Wongala Crescent turns to become Boundary Road, the vegetation is sparser. Although NB02 ends before this point, views of the proposed location of the southern end of NB03 across the tracks are available.

### NB03 (refer Figure 4-5 and associated photographs)

The majority of this precinct comprises an existing railway embankment, with the land to the east beyond the corridor falling steeply to detached dwellings in landscaped settings, all separated from the corridor by dense, mature indigenous trees and shrubs with significant “weed” infestations. There is only one location, at the foot of Azalea Grove, where views of the proposed barrier will occur. At the northern end of the precinct, a substantial existing cutting occurs. The barrier will extend the top of the cutting at its lower heights only. The end of the barrier may be visible from the adjoining public path. Views to the corridor are available.



Figure 4-3 Photo location map for NB01





Figure 4-4 Photo location map for NB02





Figure 4-5 Photo location map for NB03



This page has been left blank intentionally



# 5. Augmented visual impact assessment

## 5.1 Purpose

This Augmented Visual Impact Assessment of the proposed barriers is a supplement to the earlier analysis in the ETTT Project's approved UDLP. It has been prepared to address Condition C31(f) of the MCoA.

## 5.2 Timing

The site inspection component of the assessment was carried out between February and October 2015, and the assessment based on the visibility of the corridor and associated rail infrastructure during that time period. Recent tree clearing for the ETTT Project has occurred within the corridor during this period and these impacts have been included in this assessment.

## 5.3 Methodology

The methodology adopted for this addendum report is the same as that used for the main Urban Design and Landscape Report. It is based on the NSW Roads and Maritime Services (RMS) Guidance Note for Landscape Character and Visual Impact Assessment, which provides an accepted industry standard methodology. The landscape character assessment component is provided above in Chapter 4.

The following assessment is for visual impact only, and assesses the effectiveness of existing vegetation to screen the noise barriers, compared with the effectiveness of the proposed new landscape treatments. The assessment is been conservative in an effort to capture the fullest reasonable extent of impacts.

Consistent with RMS's methodology and the Condition of Approval requirements the following parameters were used in the assessment:

Visual receptors (primarily dwellings) to be assessed were identified by a desk top analysis and confirmed on site. They are assumed to be highly sensitive visual receptors. (The few commercial properties are assumed to be low to moderately sensitive.)

The assessment was carried out from the property boundary closest to the rail corridor.

The visual impact rating provided is the Residual Visual Impact\*. This is based on an assessment of the effectiveness of landscape mitigation strategies to screen the noise barriers compared with the existing condition (pre-works). Where new planting is possible and as described in Section 3, the mitigation strategies will be implemented to restore landscape areas disturbed during the works.

Receptors with a Moderate to High Residual Visual Impact rating will be eligible for consultation regarding additional at-receiver landscaping.

The chainmesh boundary fence is not considered as it is existing and any replacement will match existing.



### Residual Visual Impact

For most receivers, existing undisturbed vegetation will fully screen the barrier and therefore the visual impact is assessed as **Low**. Otherwise, residual Visual Impact is the difference between the existing visibility at the barrier locations (pre-works) and the visibility of the barriers once they have been installed and proposed revegetation has reached maturity. For example:

If a dwelling is assessed as having a **Moderate** existing visual accessibility rating for the view to the barrier location, it typically means that the view is filtered (by vegetation).

Then, as a result of the erection of the barrier, vegetation is removed and the view to it is open. Therefore, the post-construction visibility rating would be rated as High

The next step is to review the proposed landscaping and assess how high and dense it will be at maturity.

If at maturity the proposed landscaping (mitigation strategy) re-creates a filtered screen to the corridor (matching the existing condition) it would result in **Moderate** visibility rating.

Therefore, the Residual Visual Impact rating is scored as **Low**. This is because the visibility of the rail corridor, after the landscaping has reached maturity, would be similar to the rating given in the Existing visibility assessment.

### Existing conditions assessment

Photographic record of the view from each lot boundary looking towards the barrier (refer to Figure 5-1).

On-site assessment of Existing Visibility of the barrier with consideration to screening effectiveness of existing vegetation, rated as below:

- **High:** Open view of the barrier
- **Moderate to High:** View of the barrier that is partially screened
- **Moderate:** Lightly filtered screen or view of a section of the barrier
- **Moderate to Low:** Densely filtered view or glimpses of the barrier
- **Low:** Effectively represents a fully screened view.

### Post-construction assessment

Assessment of visibility of the rail corridor post-construction works and prior to implementation of landscape mitigation strategies. Assessed from a detailed review of the extent of vegetation clearing based on the technical landscape design drawings, rated as below:

- **High:** Open view of the barrier as principle to the view
- **Moderate to High:** View of the barrier that is partially screened
- **Moderate:** Lightly filtered screen or view of a section of the barrier
- **Moderate to Low:** Densely filtered view or glimpses of the barrier
- **Low:** Effectively represents a fully screened view.

### Residual impact assessment

Assessment of Residual Visual Impact from a detailed review of the proposed landscape treatment compared with the existing condition assessment, rated as below:

- **High:** The change from the existing condition to the post-mitigation condition is significant and assessed to be visually adverse
- **Moderate:** The change from the existing condition to the post-mitigation condition is readily noticeable
- **Low:** The change from the existing condition to the post-mitigation condition is not readily noticeable.

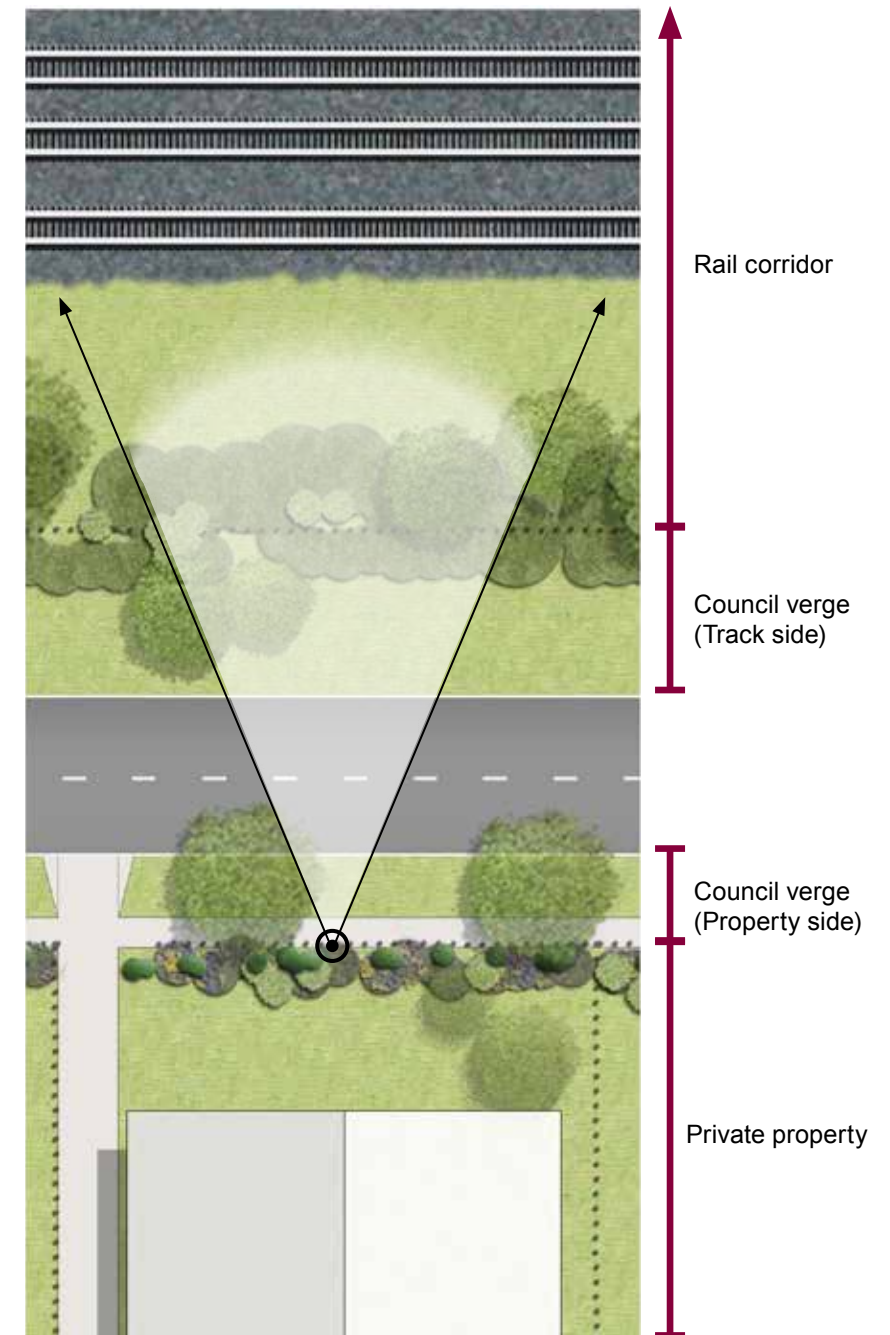

Figure 5-1 Typical photographic record location point



## 5.4 Summary of Findings

For each noise barrier, the residual impacts resulting from the assessment process are presented in the summary tables below. These tables illustrate changes in impact between the initial assessment (before any construction works, including vegetation clearing) and the assessment after the barriers have been built and revegetation is complete and has reached mature growth.

NB01

Rating	Residual Visual Impacts
High	
Moderate	2
Low	5

NB02

Rating	Residual Visual Impacts
High	
Moderate	13
Low	9

NB03

Rating	Residual Visual Impacts
High	
Moderate	1
Low	1

## 5.5 At-receiver landscaping treatment

The 16 properties identified as likely to experience a moderate visual impact as a result of the operation of the ETTT Project and residual impacts are likely to remain, will be contacted by the project team in early 2016 to discuss and identify opportunities for providing at-receiver landscaping to further screen views of the new noise barriers.

Individual consultation with the property owners will take the following into account:

- Planting of young (not advanced) shrub and hedge plants native to the area
- Location of planting to be either on private property or on the adjacent nature strip (only with the agreement of Hornsby Shire Council)
- Costs to source and plant the shrub/hedge plants will be covered by the ETTT Project, based on a pre-agreed maximum figure and to be substantiated by appropriate receipts
- Maintenance of the plants will be the responsibility of the land owner.

Once agreement is reached the land owner and ETTT Project will sign an agreement form that outlines the scope of work and other conditions

The same agreement form will be signed once the screening vegetation has been planted to confirm the works have been completed as agreed.

It is noted that time will be needed for the plants to establish and provide screening. Where possible, Council will be consulted on the possibility of planting vegetation on Council verge instead of private property. At some locations screen planting will not be possible due to site constraints (or may not be desired by the land owner).

These 16 properties are identified in the maps included in Appendix C of this addendum.



This page has been intentionally left blank

## Appendix A Relevant Standards





## Appendix A – Relevant standards

The following standards, guidelines and approvals are applicable to the UDLP and will be satisfied accordingly:

### (i) RMS / Austroads Specifications

- RMS NSW Noise Wall Design Guidelines

### (ii) Sydney Trains Policies & Standards

- Sydney Trains Crime Prevention Through Environmental Design
- EMS-09-PR-0014 Landscape and Visual System Procedure
- EMS-09-PR-0017 Pesticide System Procedure
- EMS-09-TP-0063 Biodiversity Management Plan
- EMS-09-TP-0064 Sydney Trains Bush Revegetation Technical Specification Template
- EMS-09-TP-0065 Weed Control Technical Specification Template
- EMS-09-TP-0066 - Revegetation Technical Specification
- EMS-09-GD-0067 - Vegetation Management in the Rail Corridor
- EMS-09-GD-0068 - Sowing Guide for Disturbed Site Stabilisation
- EMS-09-GD-0069 Sydney Trains Pest Animal Guide
- EMS-09-GD-0070 Common Rail Weed Identification Guide
- EMS-09-WI-0071 Sydney Trains Bushfire Hazard Reduction
- EMS-09-FM-0072 Tree Monitoring Form
- EMS-09-GD-0074 - Revegetation Guide
- EMS-09-TP-0095 - Station Garden Bed Technical Specification
- EMS-09-WI-0071 Sydney Trains Bushfire Hazard Reduction
- EMSF05 - Biodiversity Framework - Appendix 2 - Revegetation Treatments
- Sydney Trains Bush Regeneration Technical Specification Template – EMS-09-TP-64
- Sydney Trains Engineering Standard - ESC 510 Boundary Fences
- Sydney Trains Engineering Standard - SPC 511 Specification Boundary Fences
- Sydney Trains Crime Prevention Through Environmental Design
- ESC 360 Miscellaneous Structures
- ESC 510 Boundary Fences

### (iii) Project Related Documents / Briefing Documents

- ETTT Work Package No. 1549

### (iv) Australian Standards

- AS 4292.1-2006 Railway Safety Management Part 1: General Requirements
- AS 4373-2007 Pruning of Amenity Trees
- AS 4419 Soils for Landscaping and Garden Use
- AS 4454 Composts Soil Conditioners and Mulches
- AS 5100.1-2004
- AS 5100.1 Supp 1-2006

### (v) Department of Planning and Environment

- Environmental Impact Statement (EIS)
- Submissions Report
- Conditions of Approval (COA)

### (vi) NSW Police

- Crime Prevention through Environmental Design standards

## Appendix B Community Feedback





## Appendix B – Community Feedback

The Community feedback and responses provided in this appendix have been grouped into 3 categories, these are:

1. Feedback regarding the proposed noise barrier along Sutherland Road, Beecroft
2. Feedback regarding the proposed noise barrier along Wongala Crescent (Beecroft and Pennant Hills)
3. Feedback regarding the proposed noise barrier south of Pennant Hills Road Bridge, Pennant Hills

Issue	Community comment/ suggestion	Responses
<b>1 - Feedback regarding the proposed noise barrier along Sutherland Road, Beecroft</b>		
Noise barrier colour options	<ul style="list-style-type: none"> <li>• 84.6% of the respondents that outlined a preference for noise barrier colour options preferred 'Mist Green' while 15.4% preferred 'Smoke Ash' with no preference received for 'Cola (Dark Brown)'</li> <li>• The wall should be kept with the look of unpainted brick to fit into the surrounding area.</li> </ul>	<p>In response to a clear majority of residents that provided feedback expressing a preference for mist green, this noise barrier will be painted 'Mist Green'.</p> <p>It should be noted that the masonry sections of this noise barrier will not be painted and the section along the Sutherland Road carpark will be painted with anti-graffiti as it is publicly accessible.</p>
	<ul style="list-style-type: none"> <li>• Hornsby Shire Council is happy to support the colour and plant choices of residents provided the plants are endemic to the area. In general council advises that dark colours appear intrusive and light colours may be less intrusive although can attract graffiti.</li> </ul>	Noted
	<ul style="list-style-type: none"> <li>• BCCT support the proposed sections of masonry wall</li> </ul>	Noted
Vegetation	<ul style="list-style-type: none"> <li>• 80% of the respondents that outlined a preference for tree options preferred 'Blueberry Ash', 20% preferred Forest Sheoke while 'Sandpaper Figs' did not receive any votes.</li> <li>• 70% of respondents that outlined a preference for shrub options preferred 'Coffee Bush' with the remaining 30% preferring 'Narrow-leaved Geebung' and no one outlining a preference to 'Large Leaf Hop Bush'</li> <li>• 40% of respondents that outlined a preference for ground cover options preferred "False Bracken", another 40% preferred Kangaroo Grass with the remainder opting for "Variable Leaved Goodenia".</li> <li>• Large mature trees have been removed from the car park on Sutherland Road increasing the noise from the works and trains dramatically from the bridge at Copeland Road to the station. Mature trees should be planted on the footpath verge to help minimise this intrusive noise.</li> </ul>	<p>In response to community feedback, preference will be given to predominantly plant Blueberry Ash trees, some Forest Sheokes but no Sandpaper Figs.</p> <p>In response to community feedback, preference will be given to predominantly plant Coffee Bush shrubs, some Narrow-leaved Geebung shrubs but no Large Leaf hop Bush.</p> <p>In response to community feedback, preference will be given to predominantly plant False Bracken and Kangaroo Grass for the ground cover with some Variable Goodenia.</p> <p>The ETTT Project has not removed any trees from Sutherland Road commuter car park. Some tree removal has previously been undertaken in this area by Sydney Trains as part of their regular maintenance.</p> <p>As the new noise barrier along the Sutherland Road commuter car park will be built along the existing property boundary and the adjoining footpath will be incorporated into the noise barrier footing, there is unfortunately no opportunity to plant any vegetation along this section.</p>

Issue	Community comment/ suggestion	Responses
Graffiti	<ul style="list-style-type: none"> <li>• Use creepers/vines where possible to deter graffiti</li> <li>• Plant Ivy</li> <li>• A plain brick wall without vegetation is not very attractive – we would like vegetation in front of the wall (as is the case on the western side of the corridor). It is recognised that there is limited space to set back the wall. However, we urge you to be creative with a mix of the following: Set back the wall wherever possible and put bushes in front. Consider a wave pattern rather than a straight line to maximise the opportunity for planting. Where there is insufficient space for planting bushes plant a vine on the fence. If the wall is tight against the footpath a gap could be left at the bottom at intervals to allow planting (not much space is needed for a vine). There are many vine options that will not damage the brickwork. I work in the agricultural industry and am happy to help you to choose a suitable option (please ask if you would like me to help you work on this). The wall can be inspected from the back so there will be no concern that a vine will hide defects in the barrier. The roots of a well-chosen vine will be no more, and likely less invasive than the roots of bushes and trees. A suitable vine will be soft and easy to prune. There are many examples of public structures that do well with vines. A good example is outside the library at Ryde TAFE. A vine has beautified an otherwise ugly concrete structure for many years without it degrading the structure. I have been admiring it for at least two decades. It is expected that only small sections of barrier will need vines most places bushes will fit.</li> <li>• It was unclear where masonry wall extends to the north and south of station. The whole wall needs to have vegetation planted along the wire fence with non-invasive vines or small shrubs. This is also an anti-graffiti tool. As well all the wall surface ought to be painted with anti-graffiti paint which aids maintenance cost saving on future painting out.</li> <li>• We live opposite the carpark on Sutherland Road. Our concerns are graffiti and whether the barrier will be set back sufficiently to allow planting in front. Having seen these barriers along other transport corridors we consider them to be ugly on their own and not in keeping with the style of the nearby houses in Beecroft. We urge you to Use anti-graffiti paint (the section at the car park will be an easy target) and set the barrier back sufficiently to allow shrubs in front or plant clinging vine on the barrier. There are a number which are not destructive. Vegetation stops graffiti.</li> <li>• Addressing graffiti by repainting is unlikely to be effective. There are many examples of new work along the ETTT that is covered in graffiti. It is understood that there is a plan to paint over the graffiti promptly but the vandals quickly come back. Even with the intention to quickly paint over the graffiti it would not be possible for the paint team to check every section of railway every day. It can be seen in various places along railways and motorways that the over painting is obvious and unattractive, largely because the original colour fades. It should also be noted that although the railways team have gone to the effort of painting over the graffiti right at the station, there are large swathes of graffiti along the track that have not been painted over. It is expected that a large people and budget resource would be required to promptly and continuously paint over the graffiti.</li> <li>• Considering that there is already so much graffiti on the new walls along the third track, including in many difficult to access areas, it can be assumed that a wall along a footpath (the new noise barrier) will be an easy and constant target. This bus stop on Wongala Crescent just outside Beecroft Station is a good example of an easy access target. Similarly, there is graffiti on the wall beside the path on the corner of Copeland and Wongala near the memorial garden.</li> </ul>	<p>The ETTT Alliance received several suggestions to plant creeper plant/vines along the noise barriers to assist with the proposed visual impact mitigation but also graffiti management. Following consultation with Sydney Trains creepers or vines cannot be planted along the noise walls due to the adverse effect on the longevity of the noise barriers and reducing visibility during maintenance inspections.</p> <p>Sydney Trains' approach to removal of graffiti is to paint over the graffiti. An anti-graffiti coating will only be provided to hard surfaces in public areas. In these areas good access is available for maintenance staff to remove graffiti rather than to paint over it. However, an anti-graffiti coating is not being applied within the rail corridor as suggested by some members of the community. This is due to the need to use high pressure water blast to remove graffiti on top of an anti-graffiti coating. This is impractical within the rail corridor where access for equipment is extremely limited. Therefore painting using a similar colour to the substrate has been found by the Sydney Trains corridor maintainers to be the preferred and more effective solution.</p> <p>The masonry noise barrier will extend for approximately 80m along the Sutherland Road commuter carpark and this section of the barrier will be painted with anti-graffiti as it is readily accessible.</p>



Issue	Community comment/ suggestion	Responses
Additional mitigation requests:	<ul style="list-style-type: none"> <li>Our residence is on the corner of Copeland Road East and Sutherland Road. Therefore, we believe the barrier should extend further along Sutherland Road (towards Glenelg Ave) to include the area directly in front of our boundary as we have extensive noise into our home as a result of the freight trains. We are within 25m of the train line.</li> </ul>	<p>Noise barriers are only considered at locations where properties that are predicted to exceed EPA guideline trigger levels as a result of the project, are clustered closely together and noise reduction benefits can be maximised.</p> <p>Once these properties were identified, various mitigation measures, including noise barriers were assessed to determine the benefits they might provide. Where noticeable benefits are predicted, noise barriers were assessed for acoustic and cost effectiveness. The extent (location and height) of noise barriers that will be constructed are based on the findings outlined in the Operational Noise and Vibration Review (ONVR) which was approved by Department of Planning and Environment in December 2014. As such the extent of this noise barrier will not be changed.</p> <p>The approved ONVR is available on the project website at <a href="http://www.transport.nsw.gov.au/projects-northern-sydney-freight-corridor-program/epping-thornleigh-third-track/current-works">http://www.transport.nsw.gov.au/projects-northern-sydney-freight-corridor-program/epping-thornleigh-third-track/current-works</a></p>
Other	<ul style="list-style-type: none"> <li>Please either reduce the volume of the speaker announcements or extend the barrier to be above the line of noise travel to your property.</li> </ul>	<p>The volume of speaker announcements at Beecroft Station is set by Sydney Trains and cannot be altered by the ETTT Project. The noise barriers are being installed to address the noise impacts from the operation of the new third track. The height of the noise barriers was determined as part of the ONVR which was approved by DP&amp;E in December 2014. The height of the noise barrier will not be changed.</p>

Issue	Community comment/ suggestion	Responses
<b>2 – Feedback regarding the proposed noise barrier along Wongala Crescent (Beecroft and Pennant Hills)</b>		
Noise barrier colour options	<ul style="list-style-type: none"> <li>72.4% of the respondents that outlined a preference for noise barrier colour options preferred 'Mist Green' while 27.6% preferred 'Smoke Ash' with no preference received for 'Cola (Dark Brown)'</li> <li>Hornsby Shire Council is happy to support the colour and plant choices of residents provided the plants are endemic to the area. In general council advises that dark colours appear intrusive and light colours may be less intrusive although can attract graffiti.</li> </ul>	<p>In response to a majority of residents that provided feedback expressing a preference for mist green, this noise barrier will be painted 'Mist Green'</p> <p>Noted</p>
Vegetation	<ul style="list-style-type: none"> <li>70.3% of the respondents that outlined a preference for tree options preferred 'Blueberry Ash', 26% preferred 'Forest Sheoke' and 3.7% preferred 'Sandpaper Figs'</li> <li>60% of respondents that outlined a preference for shrub options preferred 'Narrow-leaved Geebung', 24% preferred 'Large Leaf Hop Bush' while 16% preferred 'Coffee Bush'</li> <li>44% of respondents that outlined a preference for ground cover options preferred 'False Bracken', 32% preferred 'Variable leaved Goodenia' and 24% preferred 'Kangaroo Grass'.</li> <li>Location plan indicated no replanting between Albert Road and creek. Why isn't landscaping proposed here?</li> <li>What steps will be taken to protect replanted vegetation? Commuters and parents of pupils at the Arden School park along the un-kerbed side of Wongala Crescent in Beecroft. In the past trees have been damaged by vehicles and grasses and shrubs have been depleted by cars parking on top of them. What barriers will be used to protect plants?</li> <li>I don't understand why any mature trees need to be removed – flexibility in re design should enable trees to be retained</li> <li>The September 2015 brochures photomontage opposite (withheld for privacy reasons) Wongala Crescent shows short and sparse planting which doesn't obscure the barrier sufficiently.</li> </ul>	<p>In response to community feedback, preference will be given to predominantly plant Blueberry Ash trees, some Forest Sheokes but no Sandpaper Figs due to low response rate.</p> <p>In response to community feedback, preference will be given to predominantly plant Narrow-leaved Geebung shrubs and some Large Leaf hop Bush shrubs and limited Coffee Bush shrubs.</p> <p>In response to community feedback, preference will be given to predominantly plant False Bracken for the ground cover with some Variable Goodenia and Kangaroo Grass.</p> <p>Minimal vegetation is being disturbed in this location and as such no re-vegetation is proposed.</p> <p>The proposed re-vegetation is contained within the rail corridor and as such is not exposed to potential damage by commuters parking on Wongala Crescent.</p> <p>The ETTT Project's intention is to minimise the amount of trees that needed to be cleared and a flexible design approach was adopted. Noise barrier along Wongala Crescent was redesigned to push it as close to the top of cuttings as possible and reduce tree removal. Varied noise barrier bay lengths will be used (between 3m and 6m) to minimise impact on tree roots.</p> <p>As a result of the re-design, only 13 trees will need to be completely removed (with several others trimmed) in order to construct this approximately 500m long noise barrier. This is a significantly better outcome than what was originally envisaged as part of the ONVR.</p> <p>In response to community feedback additional creeper plants will be planted to deter graffiti and provide further visual impact mitigation</p>



Issue	Community comment/ suggestion	Responses
Graffiti	<ul style="list-style-type: none"> <li>Please consider the use of creepers e.g. snake vine, wonga wonga vine to provide cover to the wall and reduce risk of graffiti etc. and lead to reduction in maintenance costs.</li> <li>Use creepers/vines where possible to deter graffiti</li> <li>I would suggest the ETTT provide affected residents with fridge magnets including contact details regarding removal of graffiti which is inevitable.</li> </ul>	<p>The ETTT Alliance received several suggestions to plant creeper plant/vines along the noise barriers to assist with the proposed visual impact mitigation but also graffiti management. Following consultation with Sydney Trains creepers or vines cannot be planted along the noise walls due to the adverse effect on the longevity of the noise barriers and reducing visibility during maintenance inspections.</p> <p>Sydney Trains' approach to removal of graffiti is to paint over the graffiti. An anti-graffiti coating will only be provided to hard surfaces in public areas. In these areas good access is available for maintenance staff to remove graffiti rather than to paint over it. However, an anti-graffiti coating is not being applied within the rail corridor as suggested by some members of the community. This is due to the need to use high pressure water blast to remove graffiti on top of an anti-graffiti coating. This is impractical within the rail corridor where access for equipment is extremely limited. Therefore painting using a similar colour to the substrate has been found by the Sydney Trains corridor maintainers to be the preferred and more effective solution.</p>
Barrier height / length	<ul style="list-style-type: none"> <li>Hope the barrier is high enough to be effective. 2.5 meters high doesn't seem to be very high.</li> </ul> <hr/> <ul style="list-style-type: none"> <li>As my property is in direct line of sight with the track, I am hoping that the barrier opposite my property will be at the maximum height described of 7.5m. How can I confirm this?</li> </ul>	<p>Noise barriers are only considered at locations where properties that are predicted to exceed EPA guideline trigger levels as a result of the project are clustered closely together and noise reduction benefits can be maximised.</p> <p>Once these properties were identified, various mitigation measures, including noise barriers were assessed to determine the benefits they might provide. Where noticeable benefits are predicted, noise barriers were assessed for acoustic and cost effectiveness. The extent (location and height) of noise barriers that will be constructed are based on the findings outlined in the Operational Noise and Vibration Review (ONVR) which was approved by Department of Planning and Environment in December 2014. As such the extent of this noise barrier is deemed adequate and will not be changed.</p> <p>The approved ONVR is available on the project website at <a href="http://www.transport.nsw.gov.au/projects-northern-sydney-freight-corridor-program/epping-thornleigh-third-track/current-works">http://www.transport.nsw.gov.au/projects-northern-sydney-freight-corridor-program/epping-thornleigh-third-track/current-works</a></p> <hr/> <p>Requested information was provided to the property owner.</p>
Other	<ul style="list-style-type: none"> <li>I would like to know if I can get some of the saplings of the narrow leaved ironbark please.</li> <li>I have seen glass/perspex sound screen tops. Have these been considered for a softer horizon?</li> </ul> <hr/> <ul style="list-style-type: none"> <li>Submitting as resident of Wongala Crescent and representing Pennant Hills District and Civic Trust (PHDCT) as a sub-committee member on ETTT approved by the PHDCT president - As shown in accompanying google map the slight embankment has been levelled when the gateway was put through. A large amount of road base material was brought in and compacted to make a firm roadway for very heavy vehicles. This needs to be removed and replaced with suitable soil that will not introduce weeds and non-native species as this is a heritage listed blue gum high forest strip.</li> </ul>	<p>1 sapling was provided to the resident</p> <p>The barrier panel material has been selected to provide a simple and consistent urban design palette and as such the Perspex/glass panels were not considered.</p> <p>Furthermore if the glass/perspex panels get graffiti on them, they would have to be painted in line with the graffiti management strategy employed by Sydney Trains which then defeats the purpose of them being see through.</p> <hr/> <p>Area in front of the noise barrier (where the current access gate is) will be rehabilitated to ensure new vegetation can be planted.</p>

Issue	Community comment/ suggestion	Responses
3 - Feedback regarding the proposed noise barrier south of Pennant Hills Road Bridge, Pennant Hills		
Noise barrier colour options	<ul style="list-style-type: none"> <li>90% of the respondents that outlined a preference for noise barrier colour options preferred 'Mist Green' while the remainder was split between 6.6% for 'Smoke Ash' and 3.4% for 'Cola (Dark Brown)'</li> <li>Hornsby Shire Council is happy to support the colour and plant choices of residents provided the plants are endemic to the area. In general council advises that dark colours appear intrusive and light colours may be less intrusive although can attract graffiti.</li> <li>Mist green is the most likely one to be less obvious than the other colours. I like smoke ash – but feel it will be quite dirty and not very (not legible)</li> <li>I think mist green will fit in nicely, as it's already a very green area.</li> </ul>	<p>In response to a clear majority of residents that provided feedback expressing a preference for mist green, this noise barrier will be painted 'Mist Green'</p> <p>Noted</p> <p>Noted</p> <p>Noted</p>
Vegetation	<ul style="list-style-type: none"> <li>Please add a mixture of trees and shrubs.</li> <li>Restore previous vegetation beside rail line, especially trees.</li> <li>Please consider additional planting on the embankment (Hornsby Shire Council)</li> </ul>	<p>The location of the noise barrier was chosen in order to minimise vegetation removal while meeting the noise goals identified in the ONVR. There will be a small amount of vegetation removed at the northern end of the noise barrier (on the rail side of the existing maintenance access track). The existing vegetation on the residential side of the access road will be retained to provide screening. As the noise barrier is being built directly adjacent to the existing rail maintenance access track, there is not sufficient space to plant additional vegetation in this area.</p> <p>The suggested area is outside the approved project footprint and as such no planting is proposed.</p>
Graffiti	<ul style="list-style-type: none"> <li>Major concern re graffiti. Can you plant creeping plants to cover as deterrent?</li> <li>Hopefully vines etc to grow over the "noise barrier" will grow quickly. Any "weed" would probably be a better option. I will be looking directly at the noise barrier/graffiti wall from my balcony. Not a pleasant thought. Can't imagine Sydney Trains will be maintaining the barrier and removal of graffiti any faster than they do already. All we love to look forward to on our side is a constant noise and an ugly graffiti wall. Thank you for asking though. P.S on a brighter note: The noise from construction hasn't been a problem at all.</li> <li>Would a native vine growing on the barrier/wall help cut graffiti?</li> </ul>	<p>The ETTT Alliance received several suggestions to plant creeper plant/vines along the noise barriers to assist with the proposed visual impact mitigation but also graffiti management. Following consultation with Sydney Trains creepers or vines cannot be planted along the noise walls due to the adverse effect on the longevity of the noise barriers and reducing visibility during maintenance inspections.</p> <p>Sydney Trains' approach to removal of graffiti is to paint over the graffiti. An anti-graffiti coating will only be provided to hard surfaces in public areas. In these areas good access is available for maintenance staff to remove graffiti rather than to paint over it. However, an anti-graffiti coating is not being applied within the rail corridor as suggested by some members of the community. This is due to the need to use high pressure water blast to remove graffiti on top of an anti-graffiti coating. This is impractical within the rail corridor where access for equipment is extremely limited. Therefore painting using a similar colour to the substrate has been found by the Sydney Trains corridor maintainers to be the preferred and more effective solution.</p>



Issue	Community comment/ suggestion	Responses
Additional mitigation requests:	<ul style="list-style-type: none"> <li>Why is there no noise reduction barrier on the western side closest to the new track? This is a highly populated area and the noise from the freight trains always exceeds standards on the western side. This must be rectified to avoid additional legal costs due to illegal noise pollution.</li> <li>We would appreciate a noise barrier on the western side of the tracks as well.</li> </ul>	<p>Noise barriers are only considered at locations where properties that are predicted to exceed EPA guideline trigger levels as a result of the project are clustered closely together and noise reduction benefits can be maximised.</p> <p>Once these properties were identified, various mitigation measures, including noise barriers were assessed to determine the benefits they might provide. Where noticeable benefits are predicted, noise barriers were assessed for acoustic and cost effectiveness. The extent (location and height) of noise barriers that will be constructed are based on the findings outlined in the Operational Noise and Vibration Review (ONVR) which was approved by Department of Planning and Environment in December 2014. As such, height and extent of noise barriers cannot be changed and no additional noise barriers will be built. The approved ONVR is available on the project website at <a href="http://www.transport.nsw.gov.au/projects-northern-sydney-freight-corridor-program/epping-thornleigh-third-track/current-works">http://www.transport.nsw.gov.au/projects-northern-sydney-freight-corridor-program/epping-thornleigh-third-track/current-works</a></p>
Other	<ul style="list-style-type: none"> <li>In relation to the Noise Barrier to be erected on the Eastern Side, south of Pennant Hills Road, we are concerned as we are the first house at the barrier. Even though 2a Hampden Road is sunken from Pennant Hills Road, we are still a 2 storey house and we wonder how high the noise barrier will be, as in, will the top of the barrier reach the top of our property. At the top of our property is our master bedroom and already there is lot of noise. I need your reassurance that this noise will not increase significantly due to the third track and would appreciate it if I could get some feedback about my property.</li> <li>Noise has increased since you built the concrete wall at the base of telecom building. The noise seems to bounce off it.</li> </ul>	<p>Requested height information was provided to the resident.</p> <p>All new design elements including the deflection wall under Pennant Hills Road Bridge were taken into account as part of the noise modelling undertaken to predict noise impacts at adjacent properties 10 years after operation of the new third track.</p>
Opposition to Barriers	<ul style="list-style-type: none"> <li>I oppose construction of these noise barriers. I like to see trains go past – especially steam trains. Barriers will not stop noise of freight trains leaving Epping and climbing up the valley. In fact barriers will cause a canyoning effect. Assuming a constant speed – a train climbing from Epping (say 5 minutes) will flit by these barriers in. (Say 10 seconds) with/without miniscule noise reduction overall</li> </ul>	<p>Opposition is noted however the ETTT Project is required to construct the noise barriers that the ONVR determined were required mitigation measures for the operation of the third track.</p>

# Appendix C Landscape Maps





# Appendix C – Landscape Maps

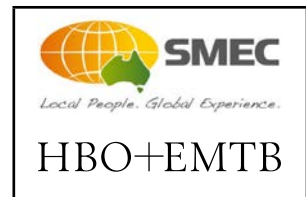
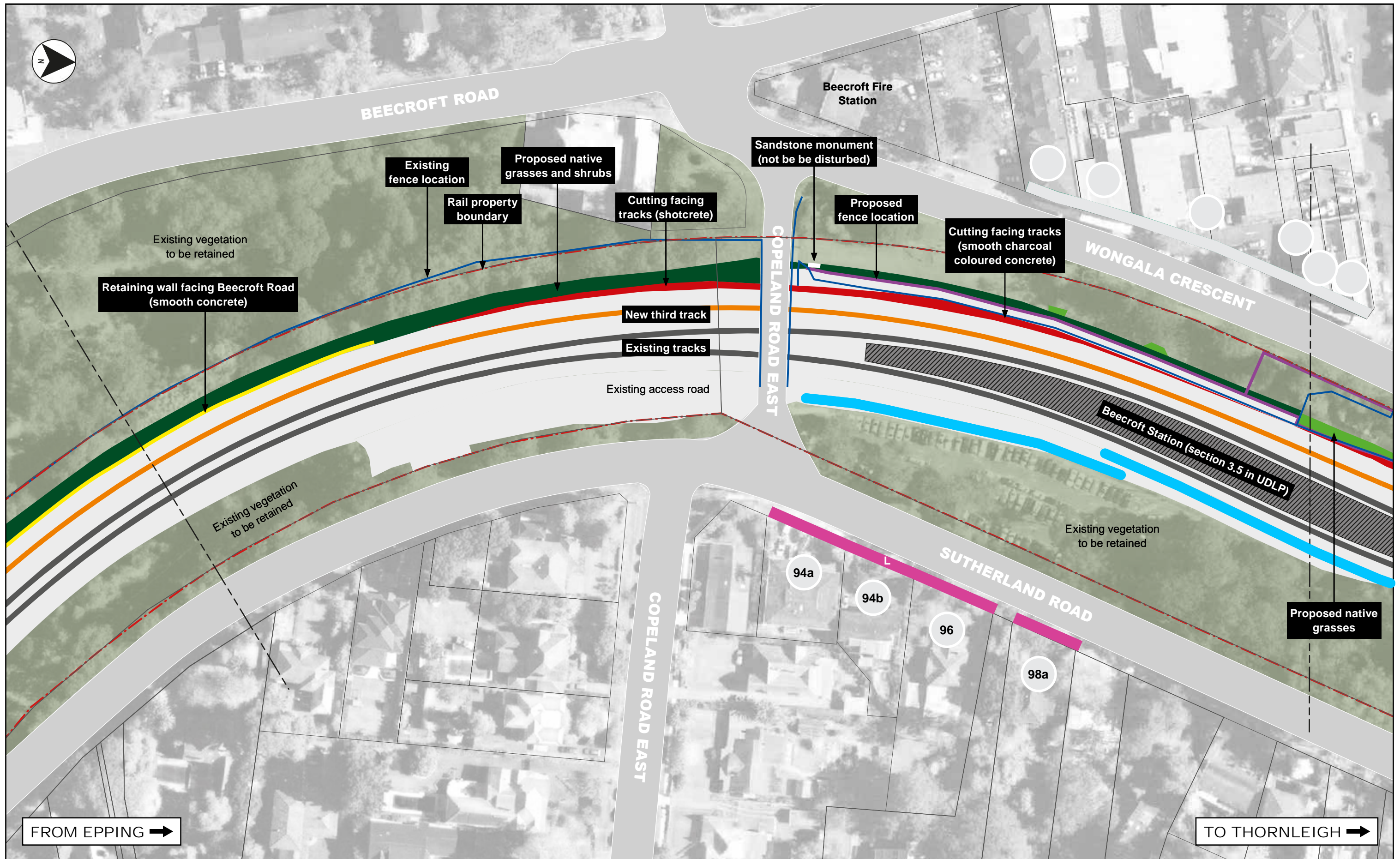

**NOISE WALL ASSESSMENT LEGEND:**

- Noise Barrier
- Revegetation Area
- 1 Street Number

**Individual Property Residual Impact assessment:**

- L Low (current assessment)
- M Moderate (current assessment)

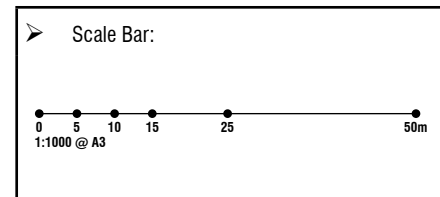

Project Name:		
<b>Epping to Thornleigh Third Track</b>		
Drawing Name	Landscape Plan	Revision
Drawing Number	ETTT-LD-10	17



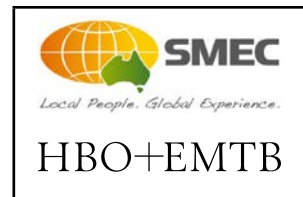
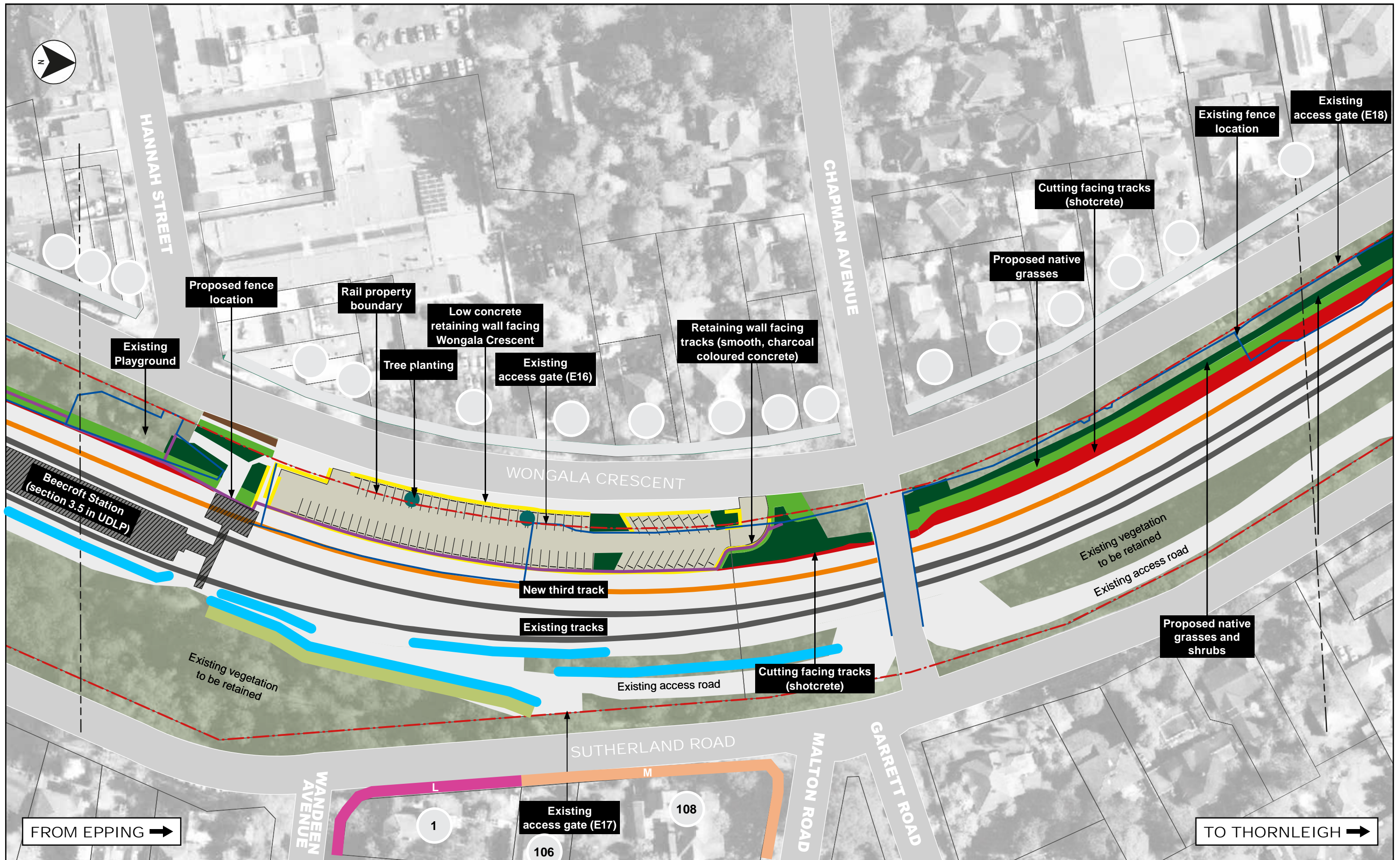

**NOISE WALL ASSESSMENT LEGEND:**

<span style="display:inline-block; width:15px; height:10px; background-color:blue; border:1px solid black;"></span> Noise Barrier	<span style="display:inline-block; width:15px; height:10px; background-color:yellow; border:1px solid black;"></span> Individual Property Residual Impact assessment:
<span style="display:inline-block; width:15px; height:10px; background-color:green; border:1px solid black;"></span> Revegetation Area	<span style="display:inline-block; width:15px; height:10px; background-color:yellow; border:1px solid black;"></span> L Low (current assessment)
<span style="border:1px solid black; border-radius:50%; padding:2px 5px;">1</span> Street Number	<span style="display:inline-block; width:15px; height:10px; background-color:orange; border:1px solid black;"></span> M Moderate (current assessment)

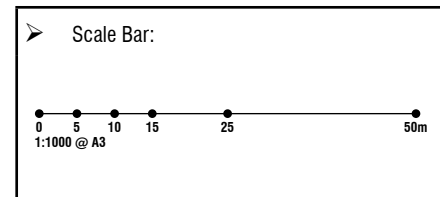

Project Name: <b>Epping to Thornleigh Third Track</b>		
Drawing Name	Landscape Plan	Revision
Drawing Number	ETTT-LD-11	17



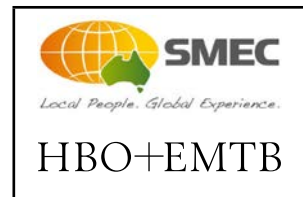
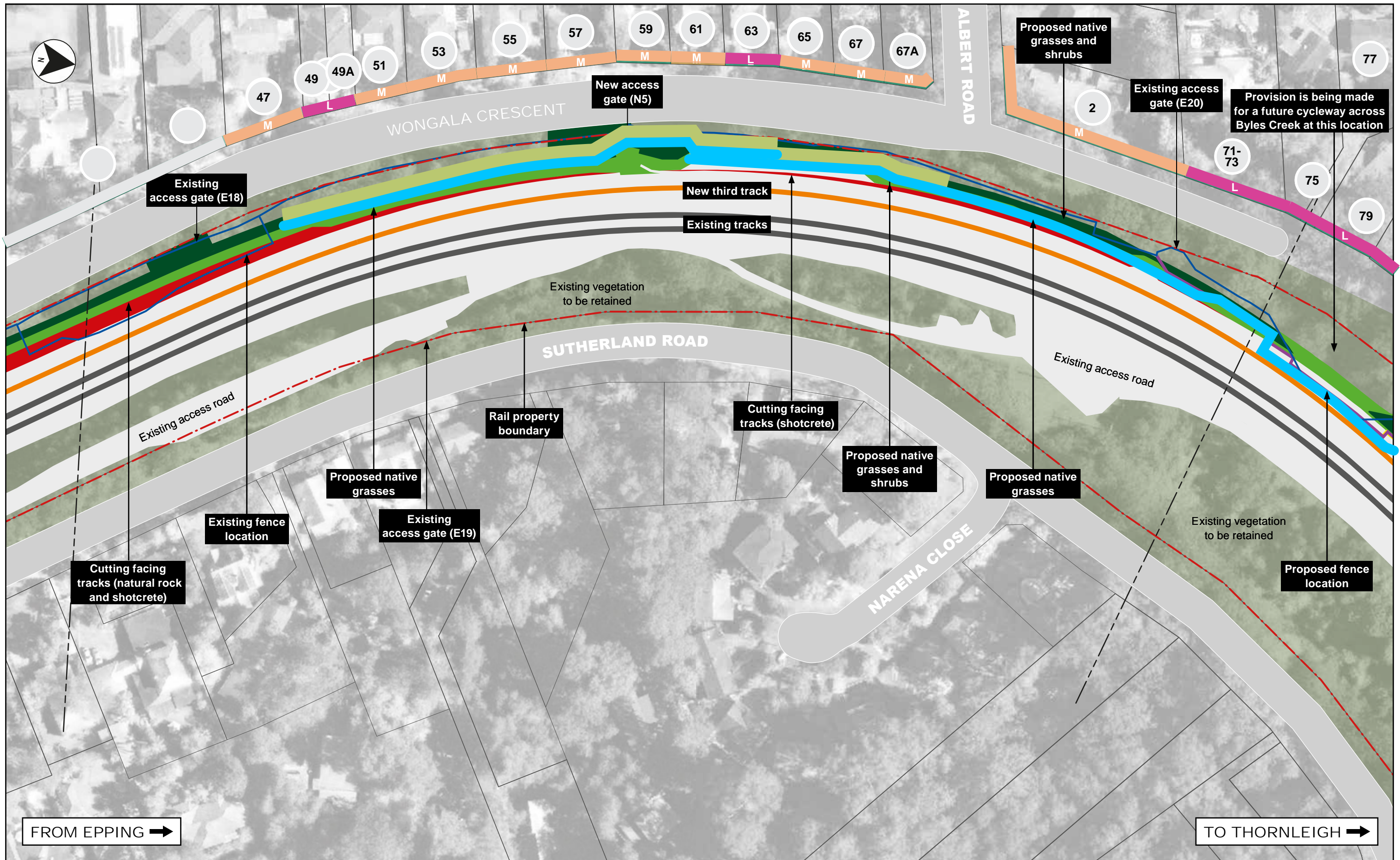

**NOISE WALL ASSESSMENT LEGEND:**

- Noise Barrier
- Revegetation Area
- 1 Street Number

**Individual Property Residual Impact assessment:**

- L Low (current assessment)
- M Moderate (current assessment)

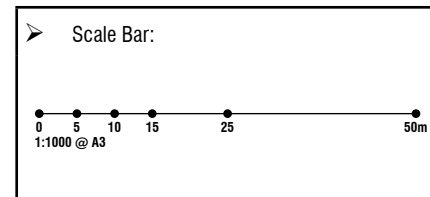

Project Name:		
<b>Epping to Thornleigh Third Track</b>		
Drawing Name	Landscape Plan	Revision
Drawing Number	ETTT-LD-12	17



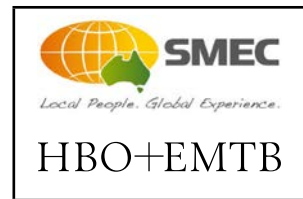
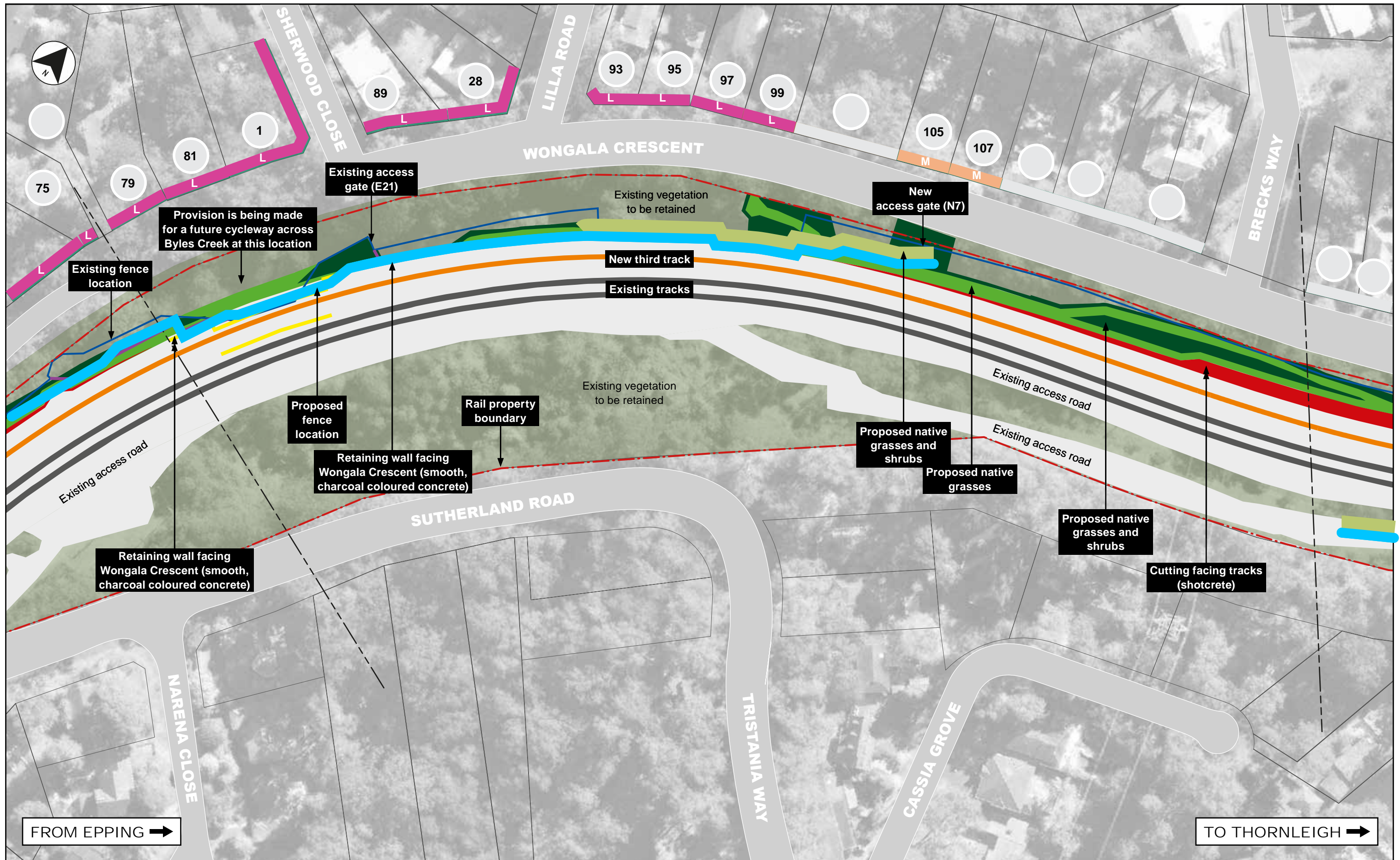

**NOISE WALL ASSESSMENT LEGEND:**

	Noise Barrier		Individual Property Residual Impact assessment:
	Revegetation Area		L Low (current assessment)
	Street Number		M Moderate (current assessment)

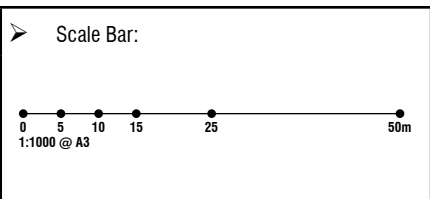

Project Name:		
<b>Epping to Thornleigh Third Track</b>		
Drawing Name	Landscape Plan	Revision
Drawing Number	ETTT-LD-13	17



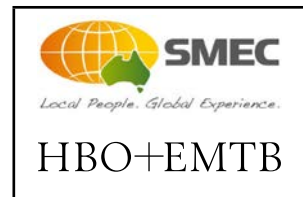
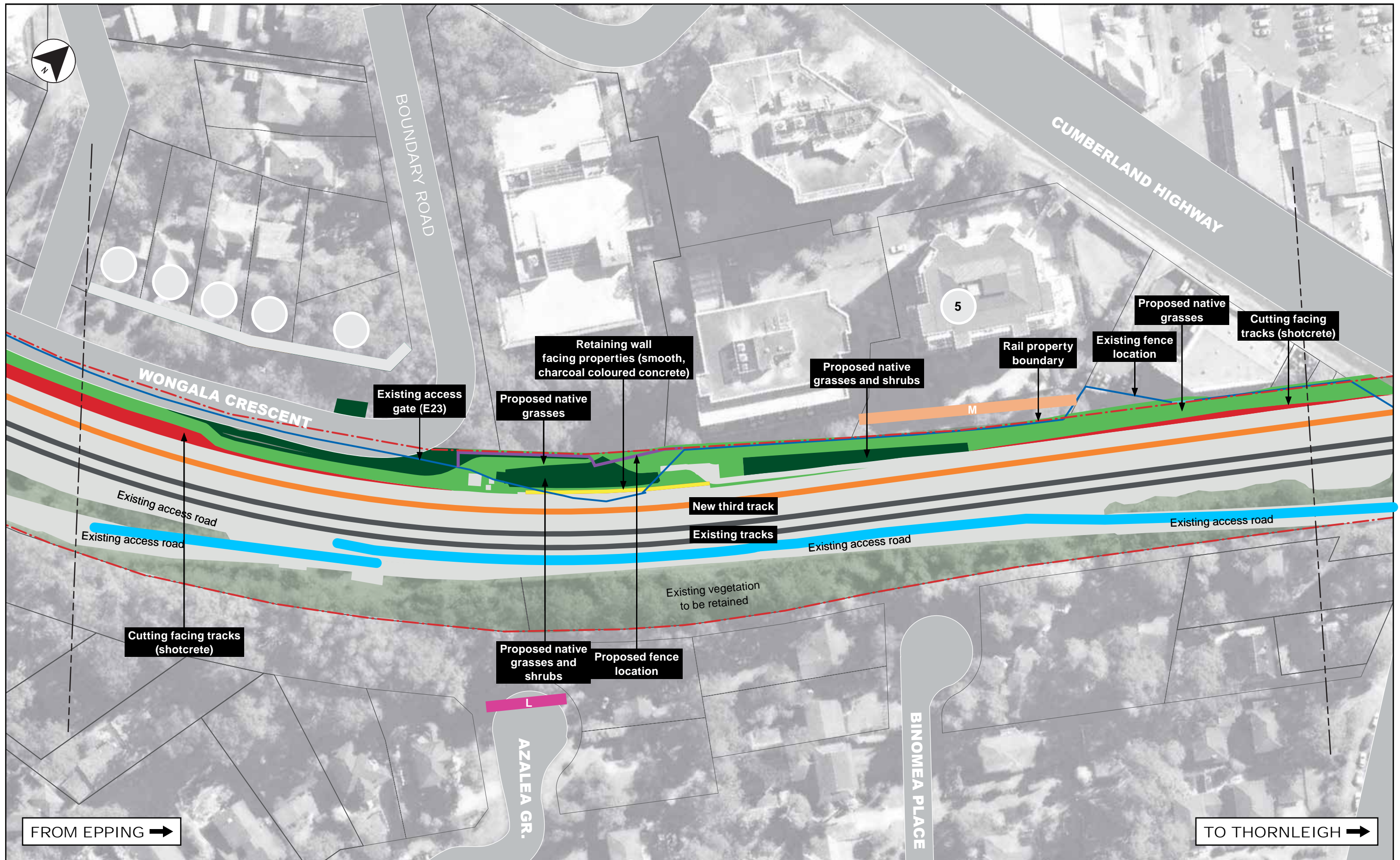

**NOISE WALL ASSESSMENT LEGEND:**

- Noise Barrier
- Revegetation Area
- 1 Street Number

**Individual Property Residual Impact assessment:**

- L Low (current assessment)
- M Moderate (current assessment)

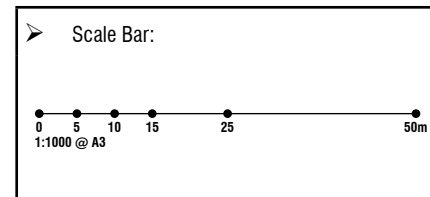

Project Name:		
<b>Epping to Thornleigh Third Track</b>		
Drawing Name	Landscape Plan	Revision
Drawing Number	ETTT-LD-14	17



This page has been intentionally left blank